

International Conference on ICT Innovation and Application (ICIIA2007)

Agent-Based Collaborative Environment

Zhongzhi Shi
shizz@ics.ict.ac.cn

Institute of Computing Technology
Chinese Academy of Sciences



中国科学院计算所
INSTITUTE OF COMPUTING TECHNOLOGY

Acknowledgement



- China Basic Research Programme 973
- China High-Tech Programme 863
- National Natural Science Foundation of China
- Ministry of Information Industry, China
- Knowledge Innovative Programme of CAS

Outline

- **Introduction**
- **Unified Communication**
- **Agent Collaboration**
- **Agent Grid Intelligence Platform**
- **Applications**
- **Conclusions**

Informatization

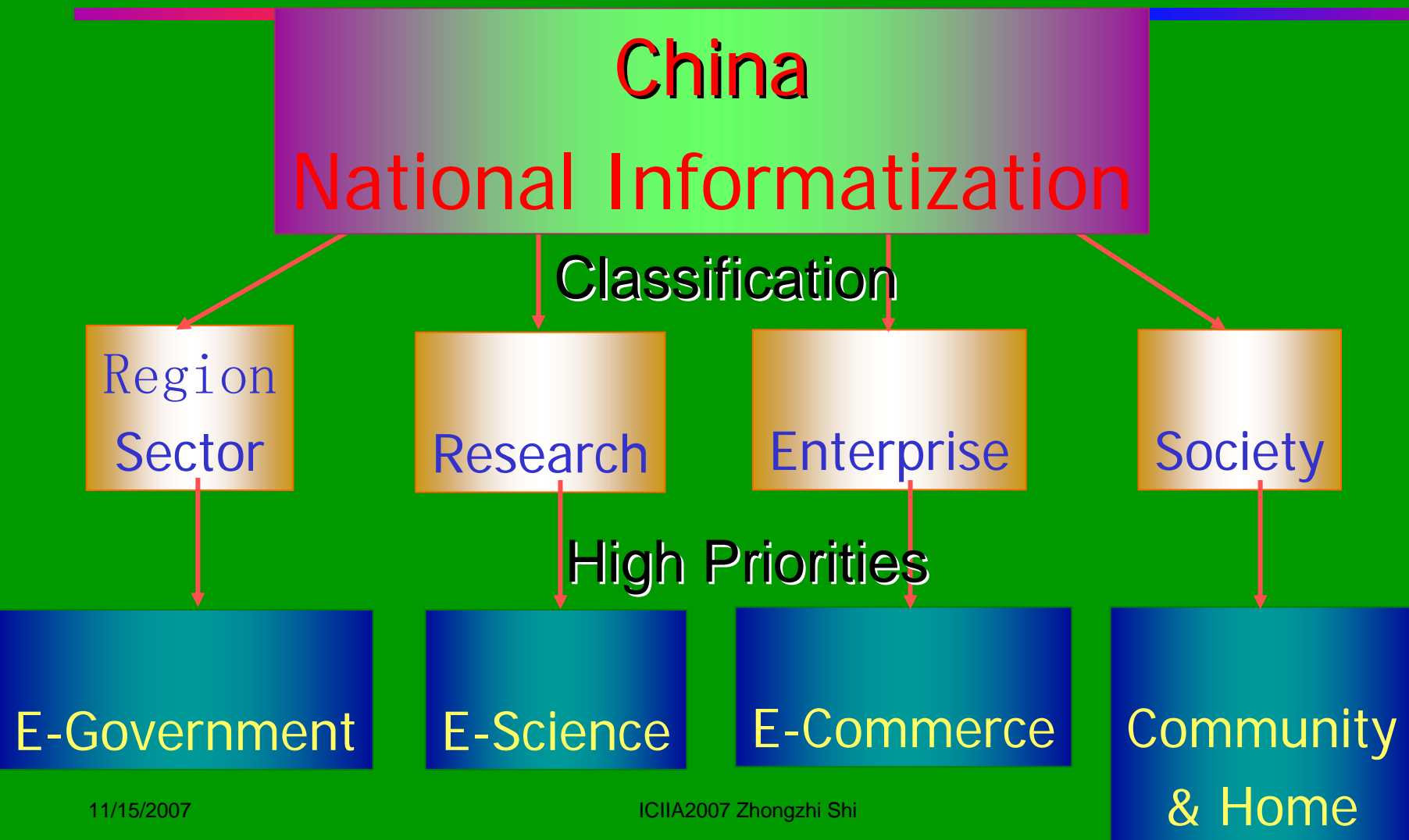

e-Government

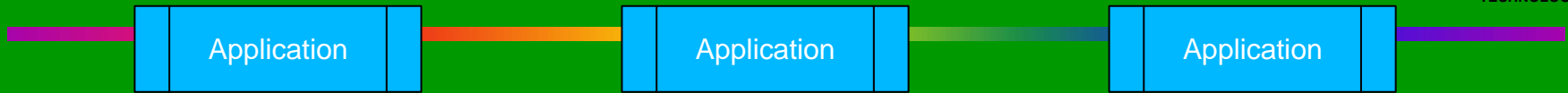

Personalization Layer

e-Gov Services Layer

Business Layer

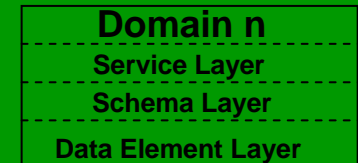
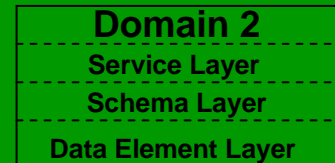
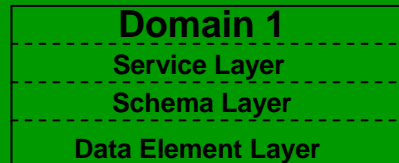

Service Oriented Layer

Common Web Services
SOA

System Software --- [O.S + DATABASES + Common PROTOCOLS]

Common Computing Hardware

Computing
+
Storage

Access
Devices

Communication Layer

e-Science



中科院计算所
INSTITUTE OF COMPUTING
TECHNOLOGY



Whipple γ -ray



Chandra



Oak Ridge



1.2m



SIRTF



Hubbl



MMT



VLA



Smm array



Antartica submm



Magellan 6.5m

e-Commerce



Business Managers



Content Providers

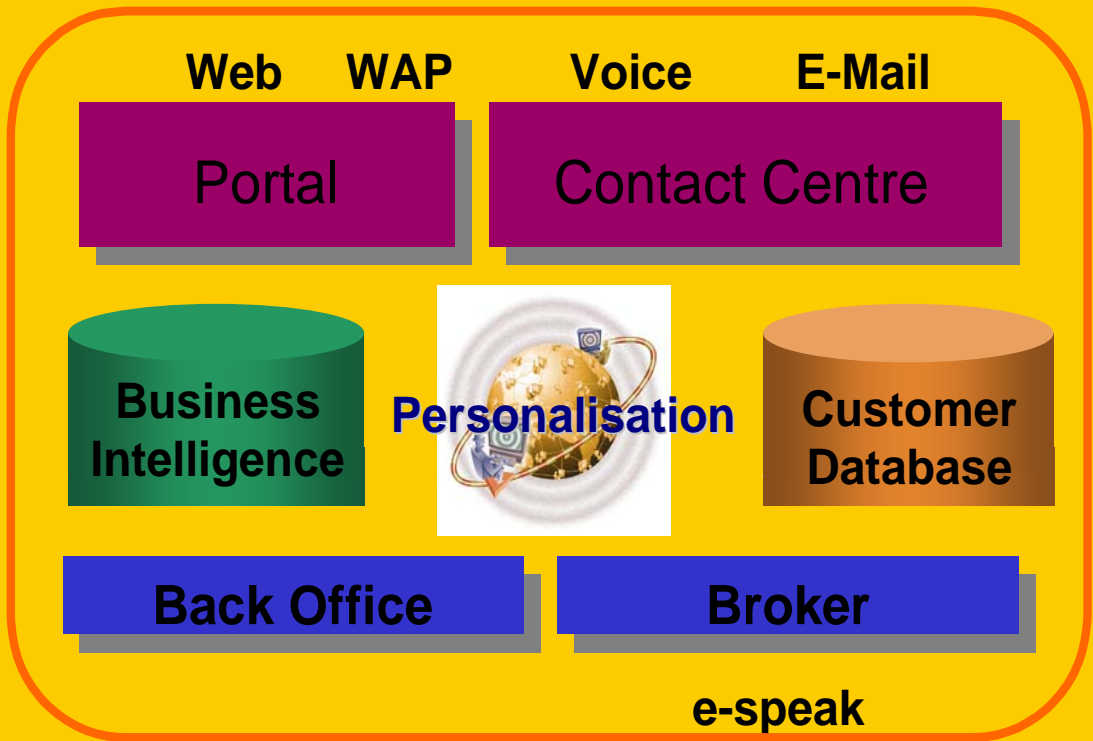

Taxis

Tours

Payment

Hotels

Airlines

Digital Business Architecture

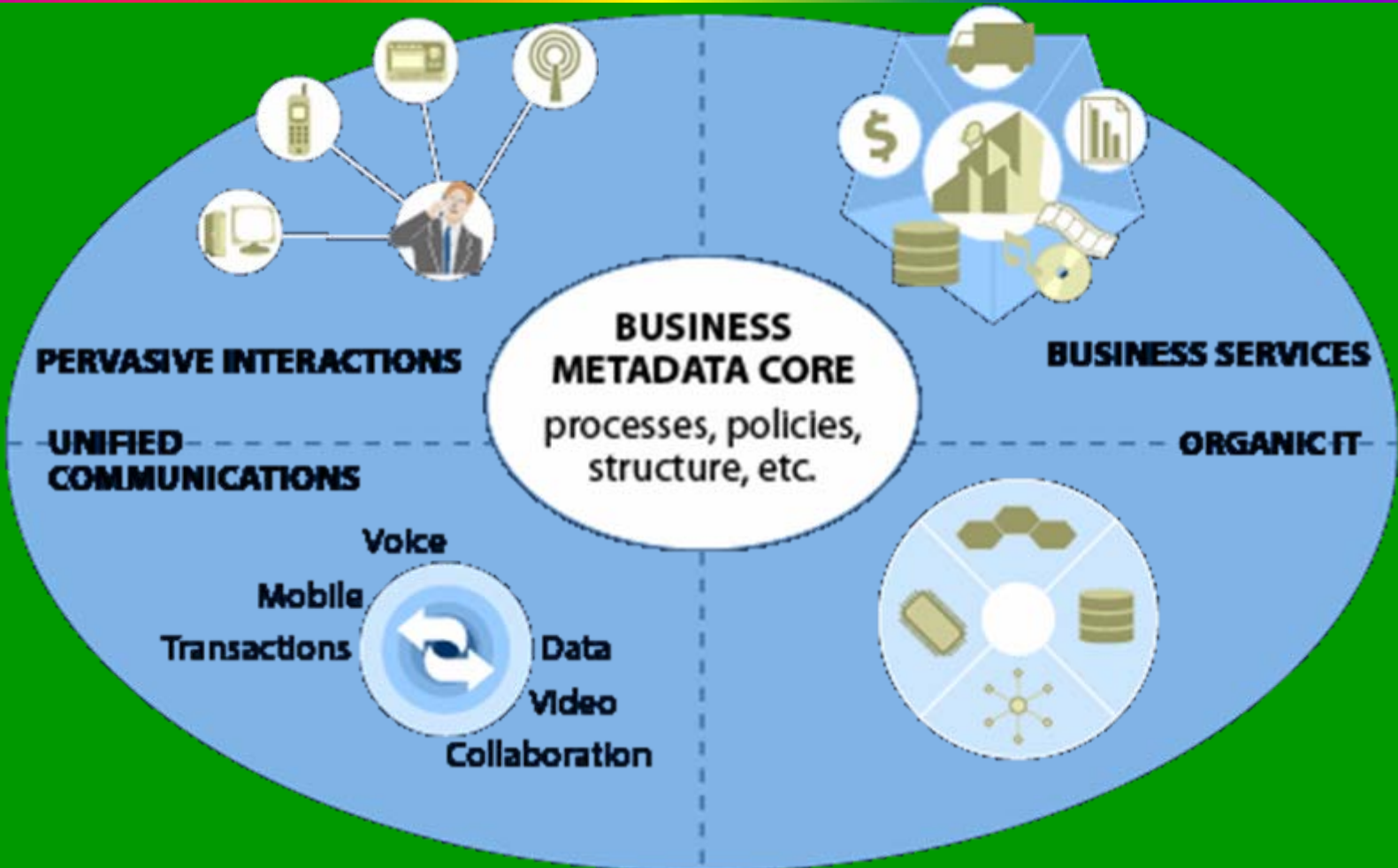

Business Services in the digital world

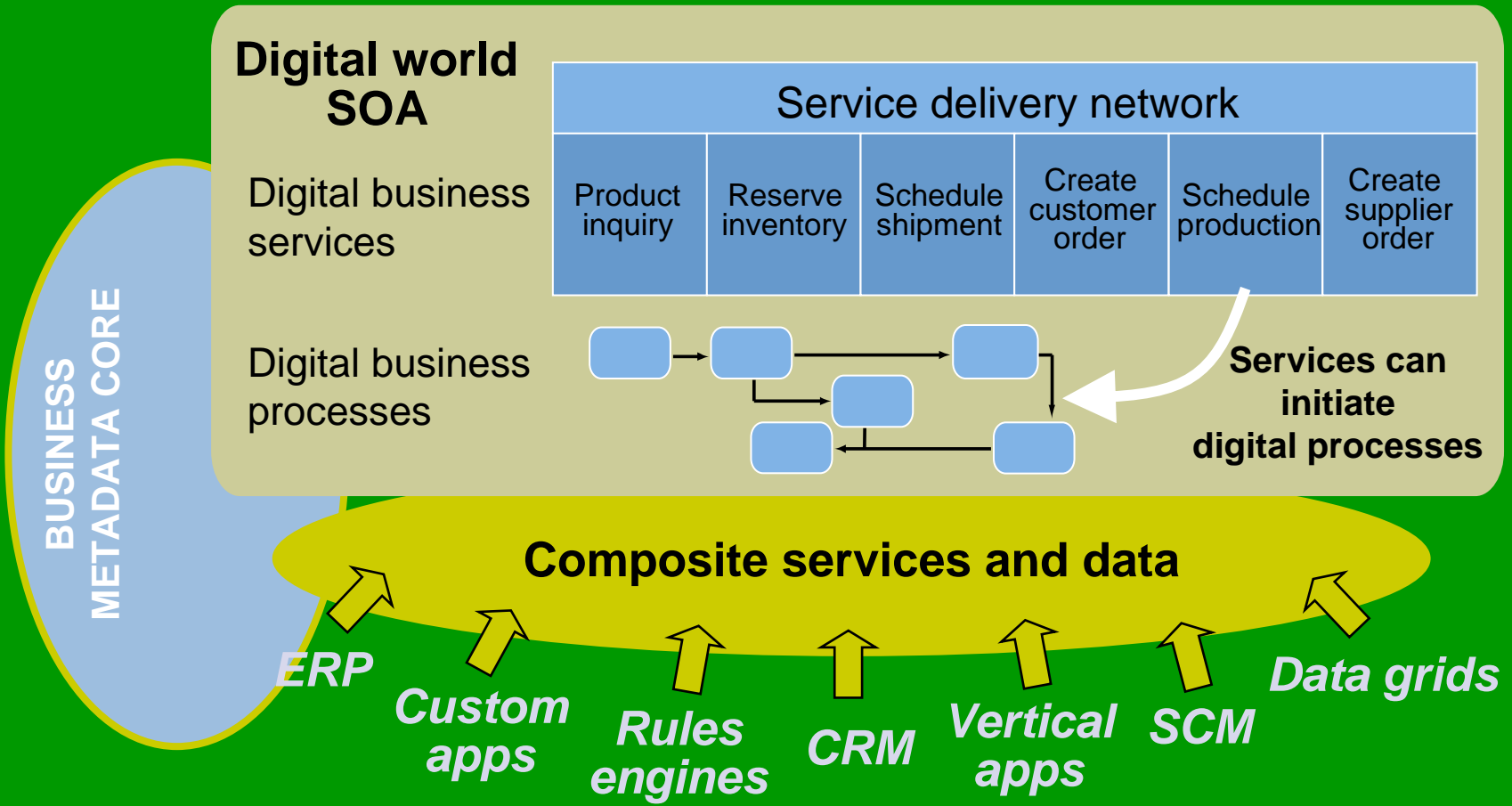

Outline

- **Introduction**
- **Unified Communication**
- **Agent Collaboration**
- **Agent Grid Intelligence Platform**
- **Applications**
- **Conclusions**

Cisco Unified Communications

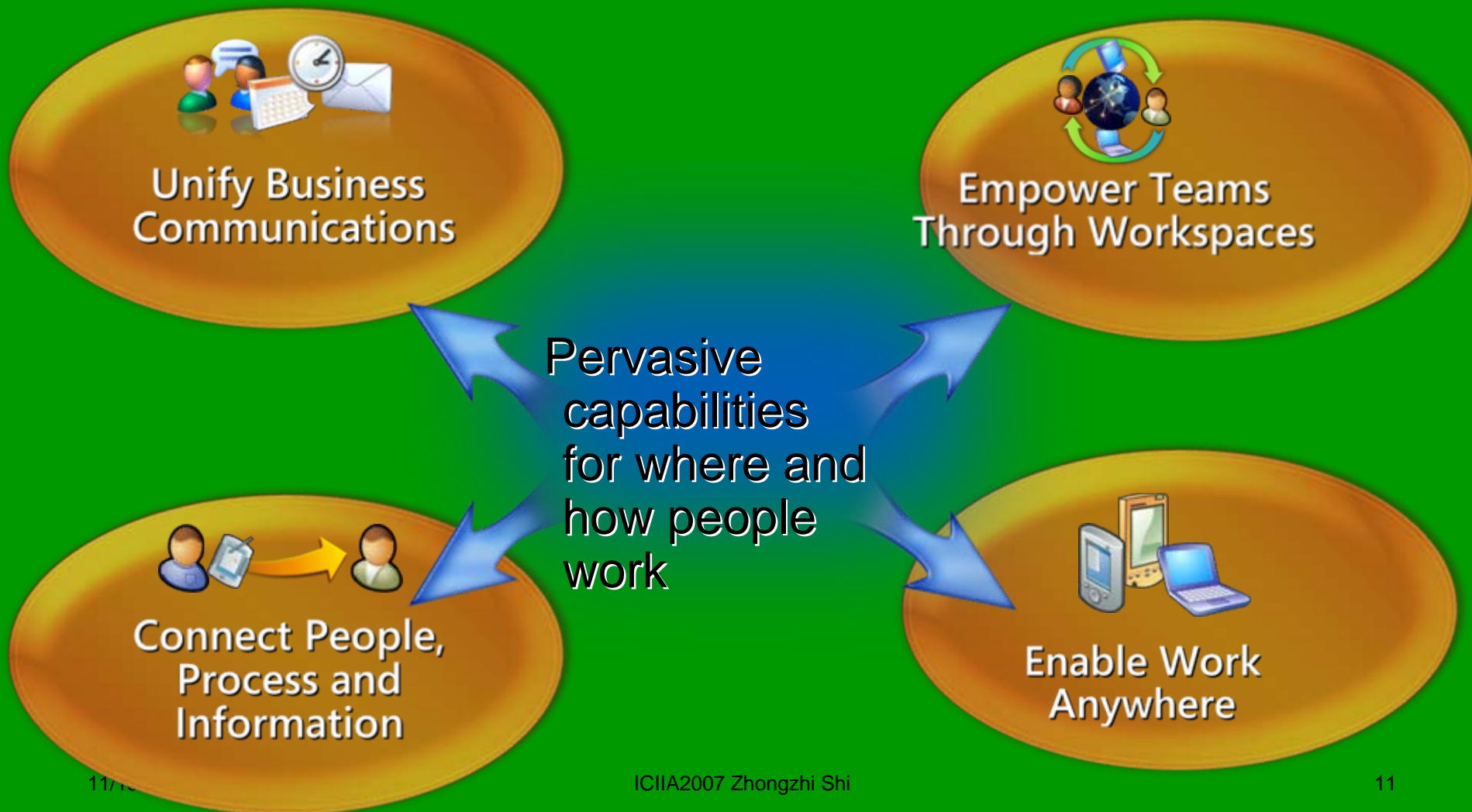

Communications Convergence

1 Communication Capabilities

- Mobile Phones
- E-mail
- Voicemail
- Fax

1998

2000

2002

2004

2006

2008

2 Integrated Communication Solutions

- IM and Presence
- Web and Video Conferencing
- VoIP
- PBX Integration
- Integration with Applications

ICIFA 2007 Zhongzhi Shi

3 Communications Convergence Occurs

- IP Telephony
- Mobile/Remote Solutions
- Horizontally Integrated Communications
- Expanded VoIP Scenarios
- Common Directory
- Standards Based

People-Centric Communications

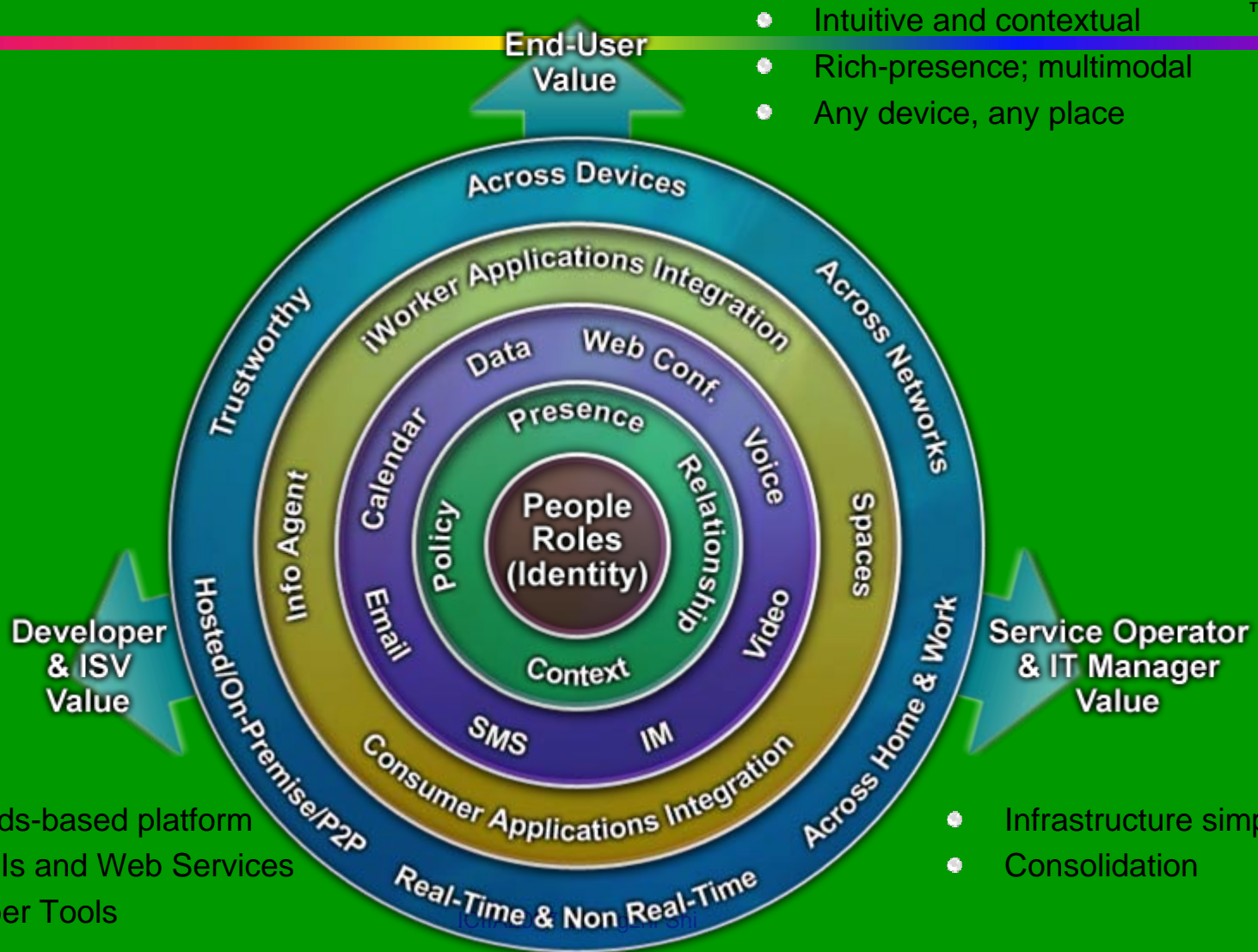

2007 Office System

Infrastructure to streamline the way people do business

Unified
Communications
And Collaboration

Business
Intelligence

Enterprise Content
Management

Workflow

Search

Business
Data
Catalog

Extensible
UI

Open
XML File
Formats

Website
And
Security
Framework

Secured, Well-Managed Infrastructure

Microsoft Unified Communications

Innovative Communications With Revolutionary Economics



中科院计算所
INSTITUTE OF COMPUTING
TECHNOLOGY

Services

Microsoft
Exchange
Hosted Services

Microsoft Office
Live Meeting

Servers

Microsoft
Exchange Server

Microsoft Office
Live Communications Server

Clients

Microsoft Office
Outlook

Microsoft Office
Communicator

Microsoft®
Office RoundTable™

Mobility

Microsoft Office
Outlook Web Access

Microsoft Office
Communicator
Web Access

Microsoft Office
Communicator
Mobile

Windows
Mobile

E-mail and Scheduling

Presence and Availability

*Enterprise Instant
Messaging*

people it ready

Audio / Video / Web Conferencing

Telephony

Developer Platform

Unified Messaging



Microsoft's Unified Communications Roadmap

Today

E-mail and Scheduling

Web Conferencing

Presence and Availability

Enterprise Instant Messaging

Remote Call Control

Q2 2007 Additions

Unified Messaging

Regulatory/Compliance

Immersive Meetings

Audio, Video and
Web Conferencing

Soft and IP Phones

IP Voice Call Management

Unified Messaging

Simple to
deploy and
manage

Consistent with
Exchange site
consolidation

Reasonable
Price Point

The right
set of
features

Highly
reliable

Great end-
user
experience

Admin benefits

- All messages in one inbox – e-mail, voicemail, fax
- Single point of administration
- Single training, troubleshooting, etc
- Reduction in cost and complexity by managing one single directory infrastructure
- Single security infrastructure
- Allows for site consolidation of voicemail systems

End User benefits

- Receiving Fax
- Voice Access to Exchange system
- Speech-enabled Auto Attendant – directory dialing, customized menus

Lower price point

- Exchange UM comes in at a lower price point than competing systems
- More importantly – cost savings around management, reduced complexity

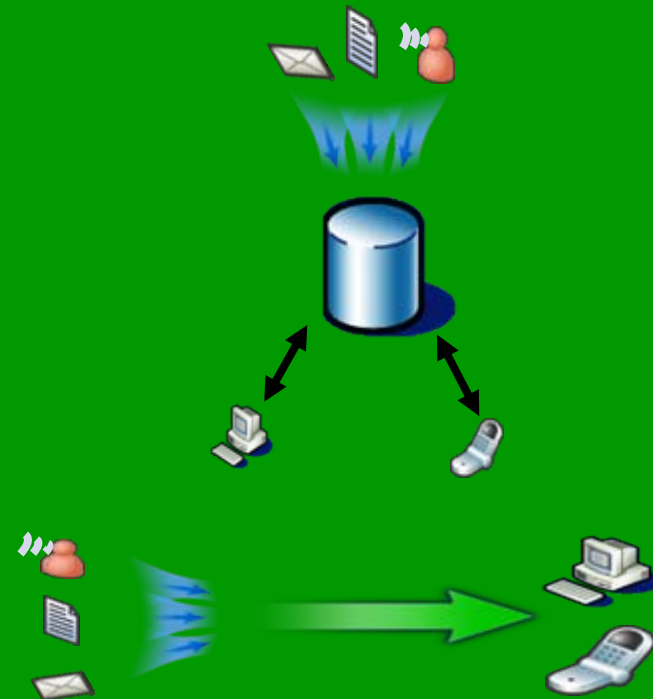

We are building a TCO/ROI tool that will capture the cost savings more granularly depending on the customer's environment

Exchange Server 2007 Architecture With UM



- Simple to deploy and manage
- Consistent with Exchange Server 2007 site consolidation
- Reasonable price point
- Right set of features rather than all features
- Highly reliable

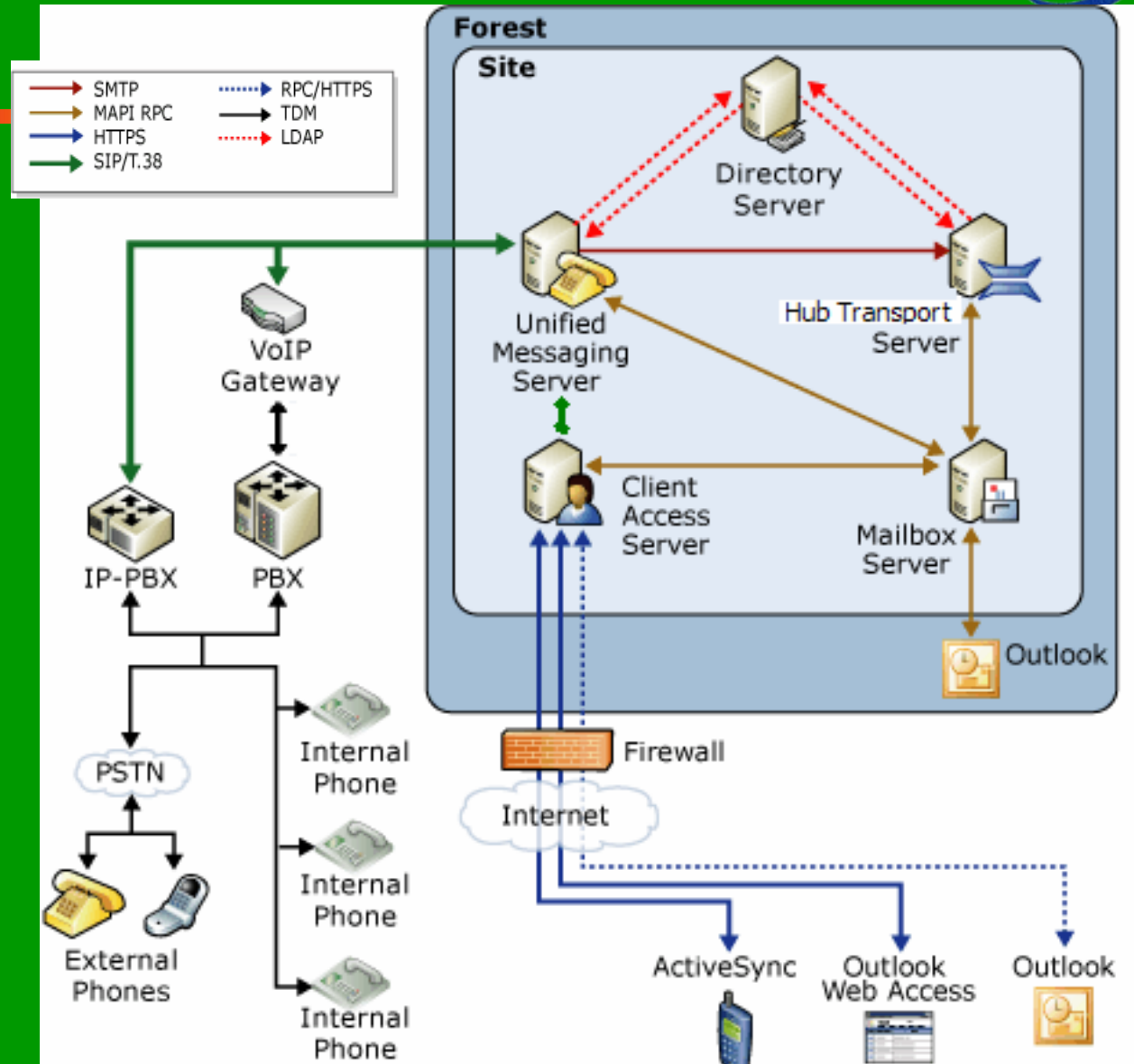

Exchange UM Solution

Availability/Fault Tolerance/Consolidation

- Gateway down → Configure multiple gateways on PBX (N+1 redundancy). PBX hunt groups direct calls to an available gateway
- UM Server down → Configure multiple UM servers (N+1 redundancy) at the consolidated Exchange site. Gateways route calls to an available UM server
- Mailbox Server down → Messages queued

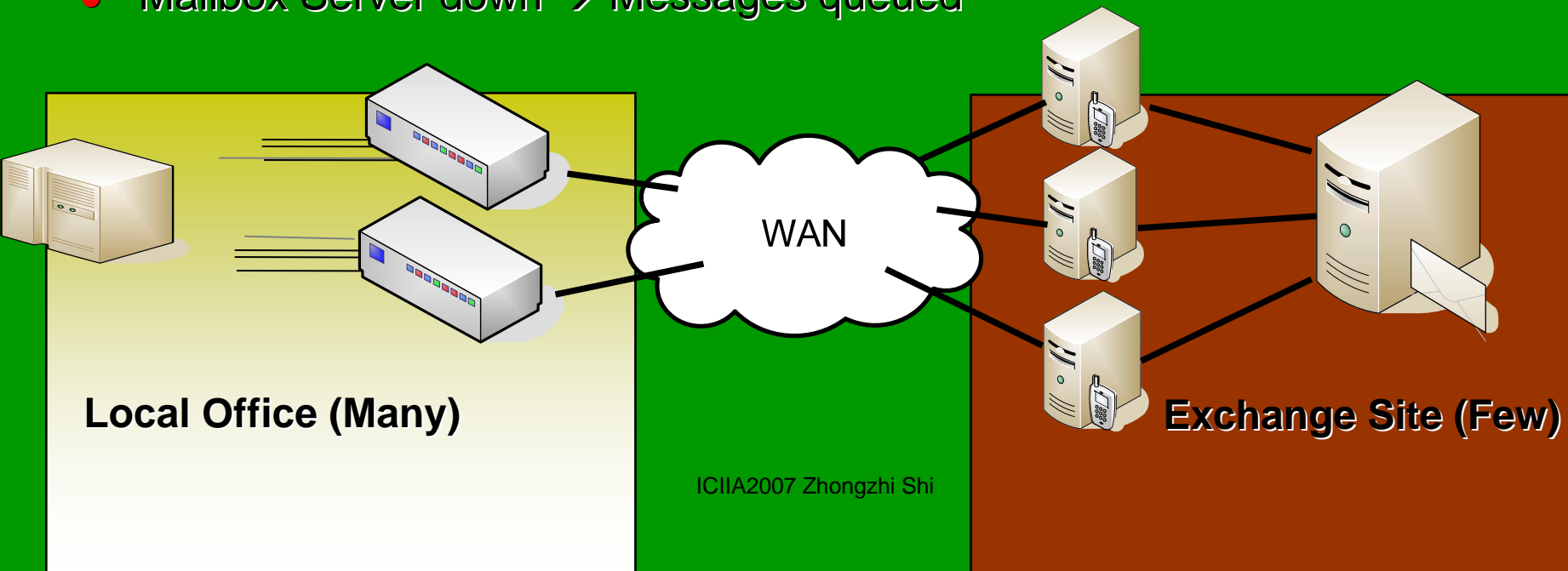

Outline

- Introduction
- Unified Communication
- Agent Collaboration
- Agent Grid Intelligence Platform
- Applications
- Conclusions

Agent Collaboration

- ACL
- Working Flow
- Ontology-based Knowledge Management
- Policy Driven
- Planning

Collaborative Architecture

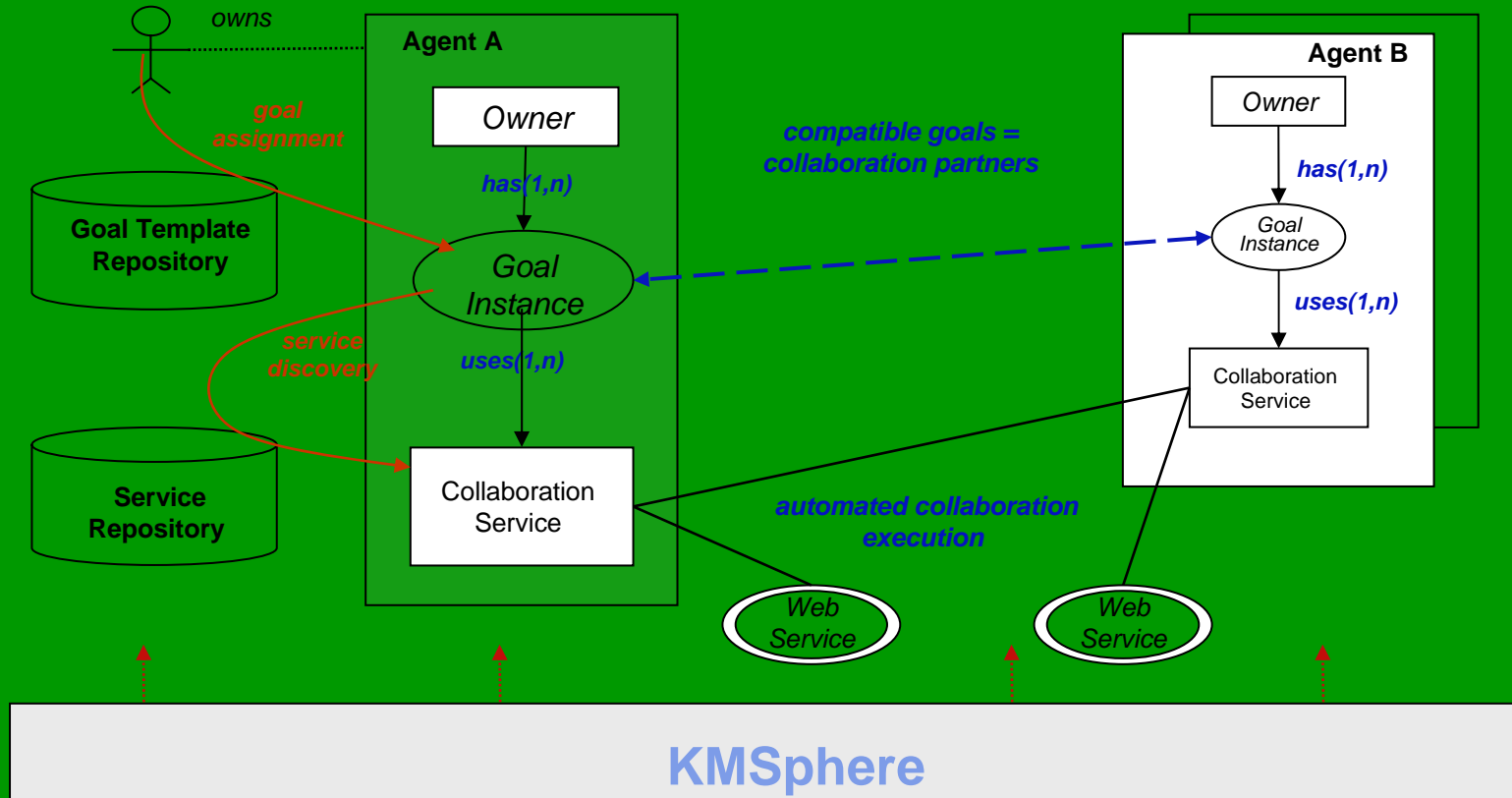

KMSphere

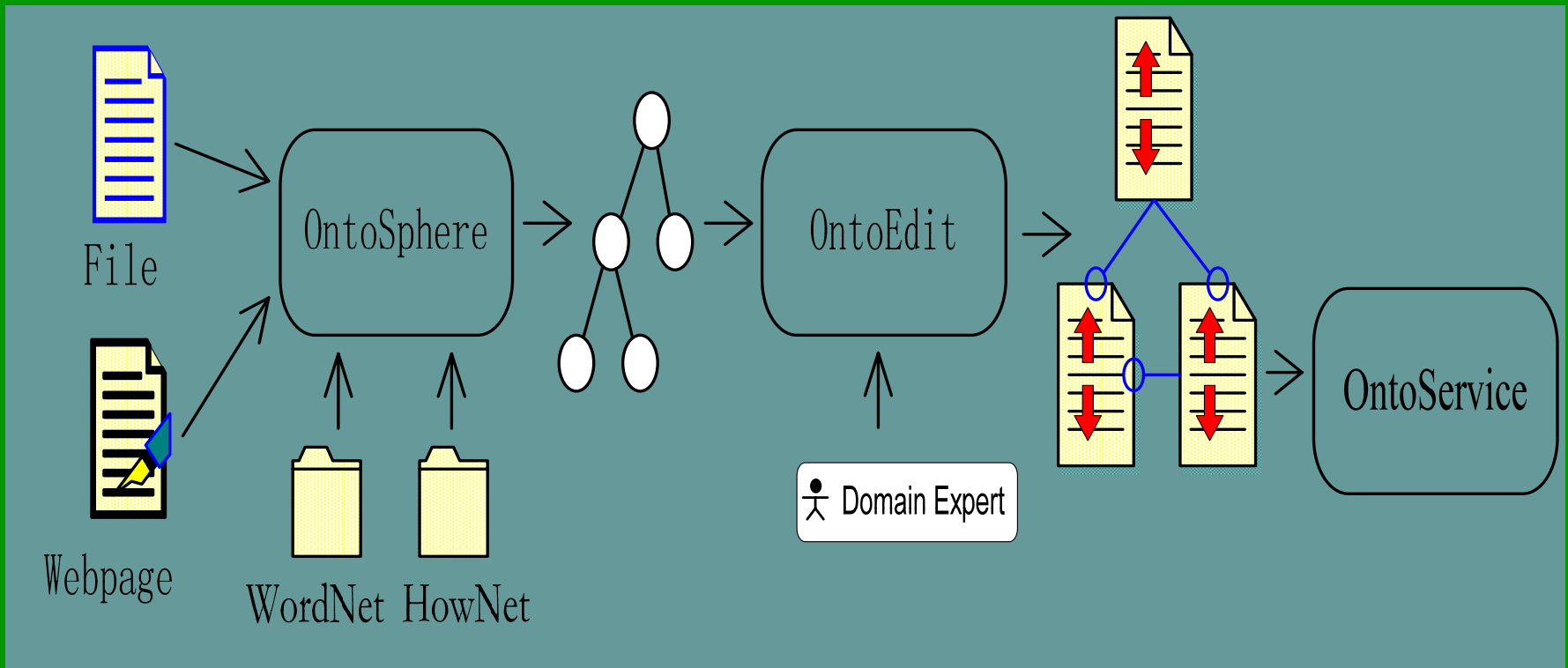

KMSphere



中科院计算所
INSTITUTE OF COMPUTING
TECHNOLOGY



Knowledge
Application

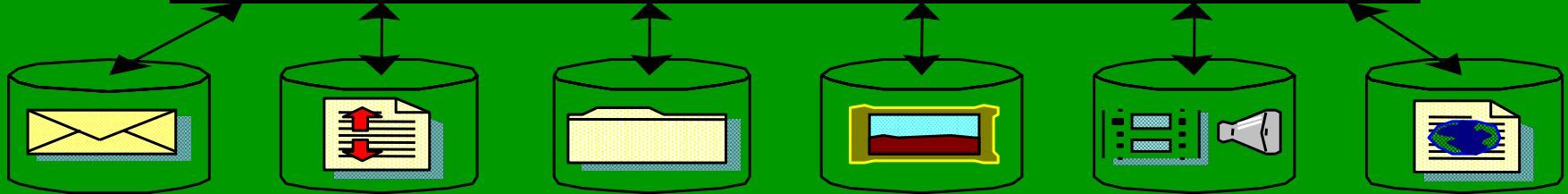
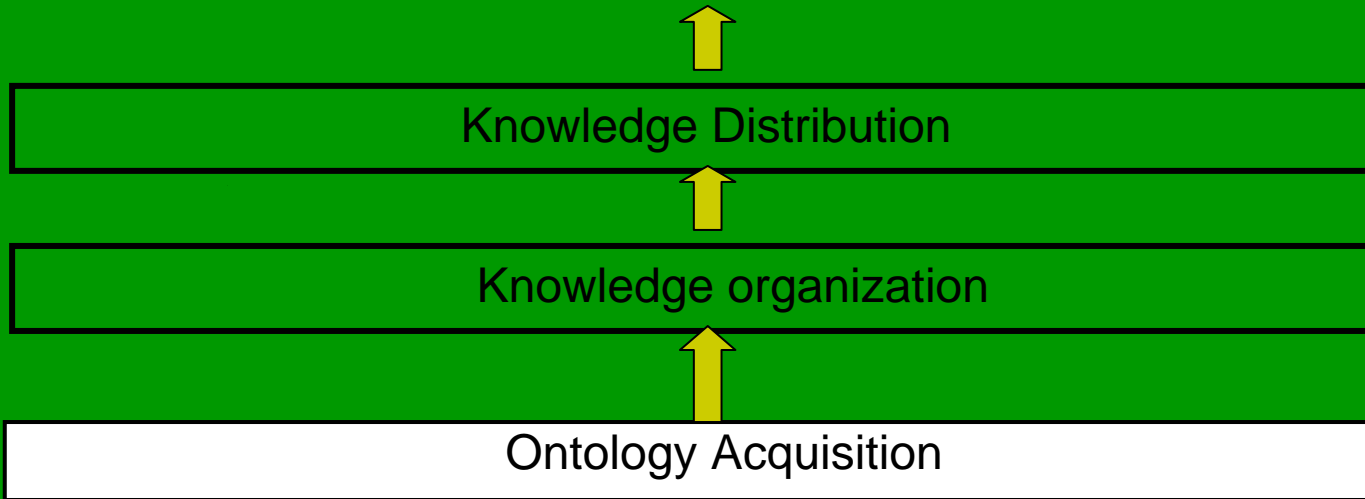

Email

Document

File

Image

Video

Web

KMSphere

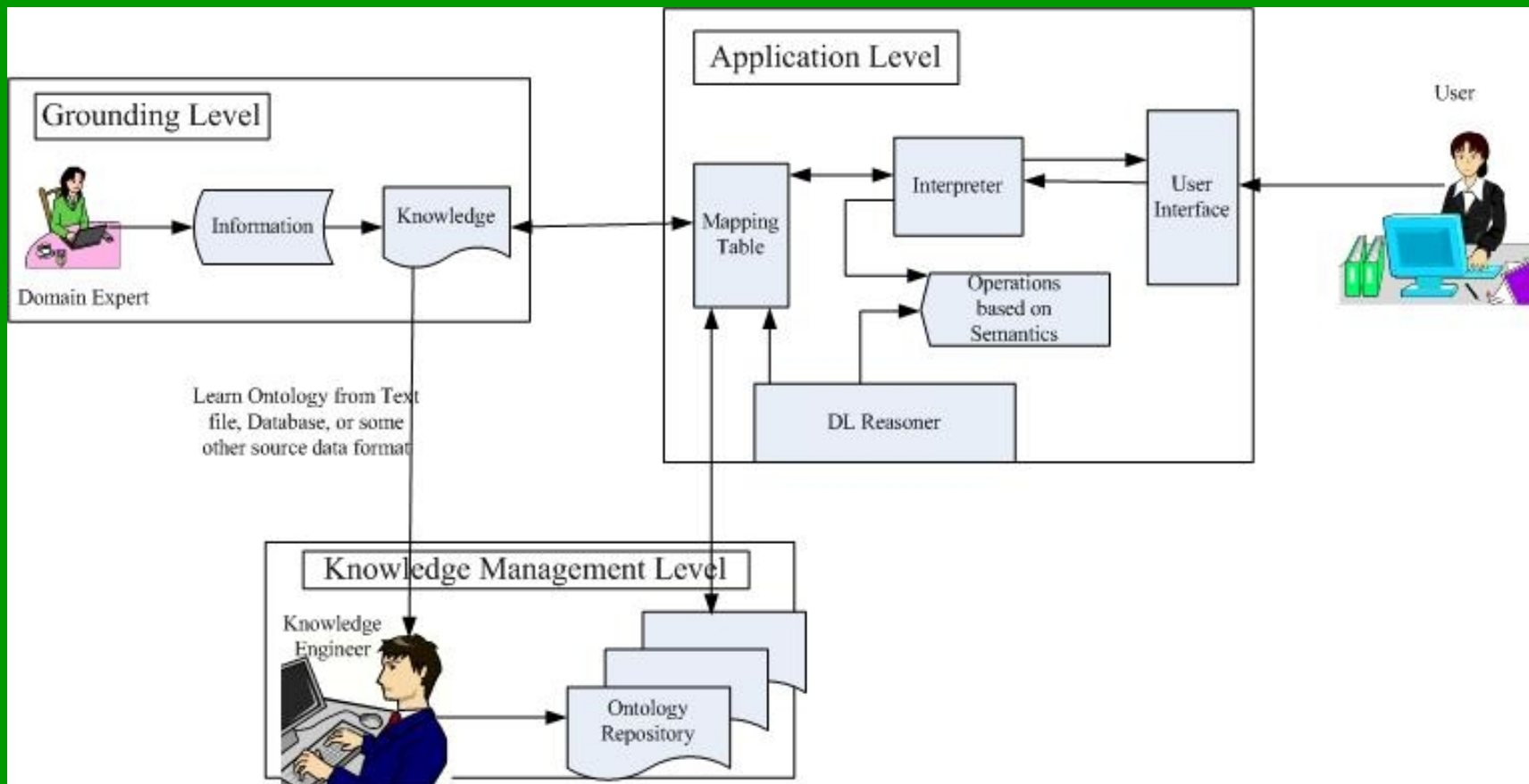

KMSphere Demo

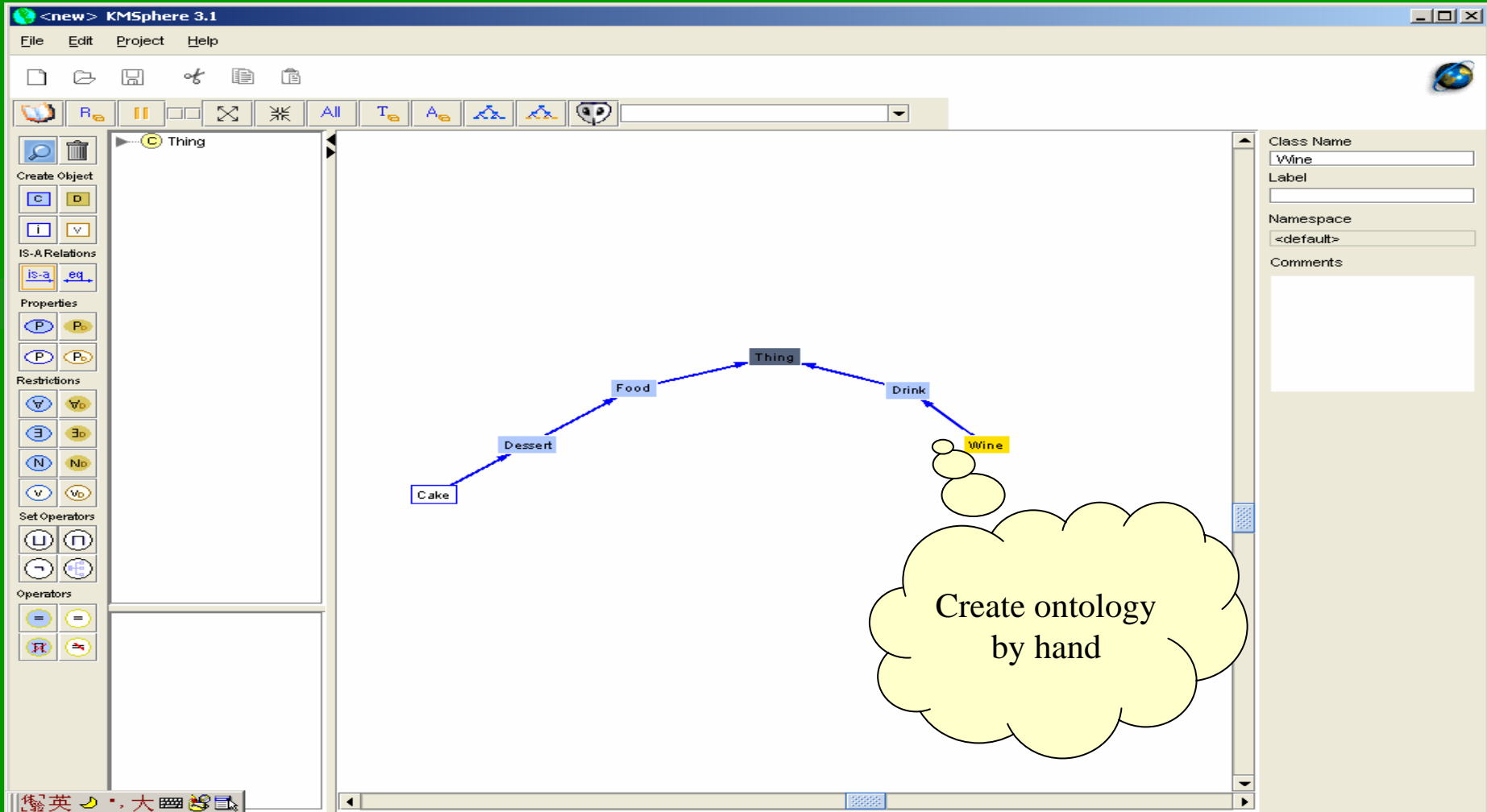

KMSphere Demo

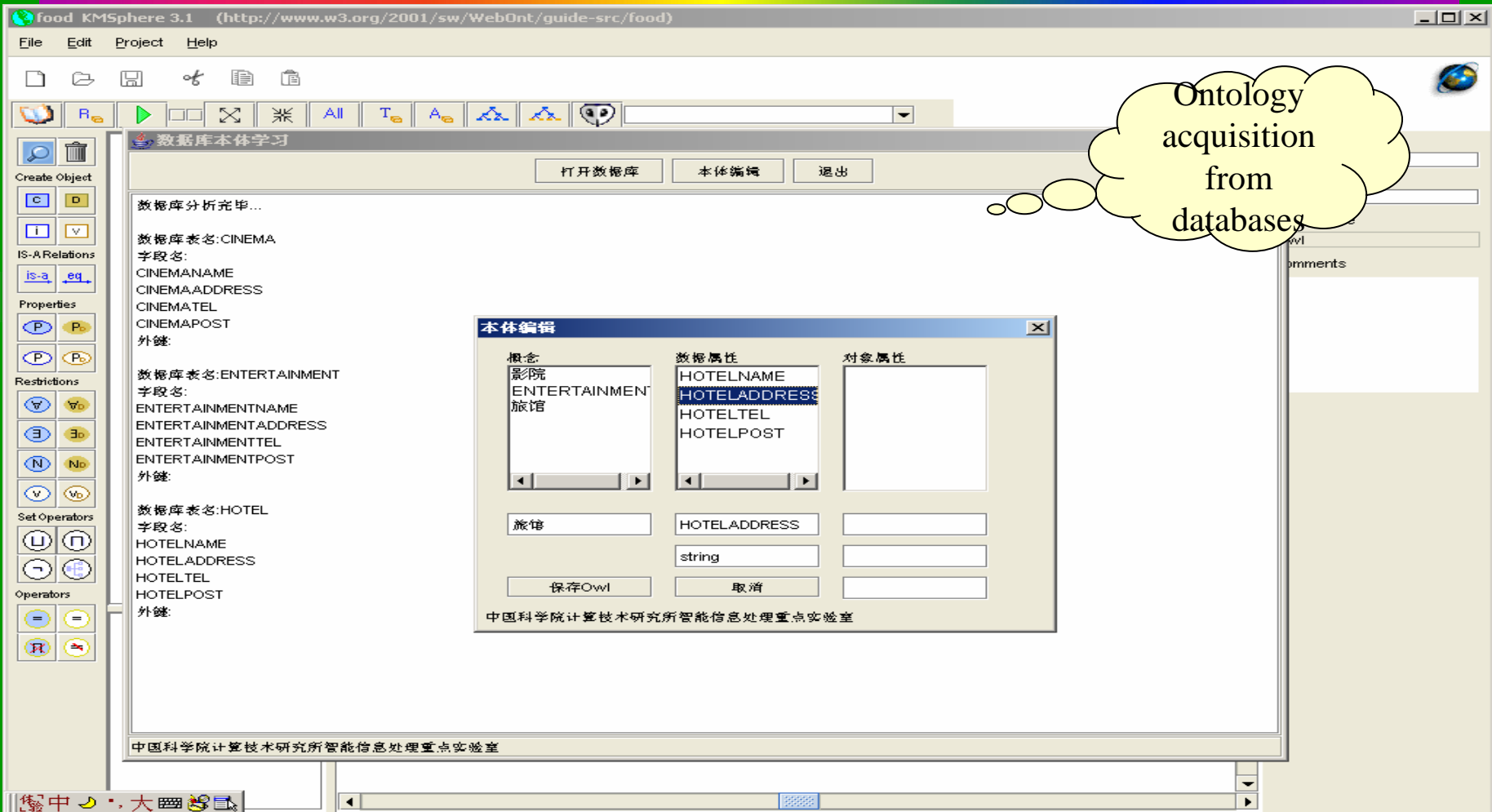

The screenshot shows the KMSphere 3.1 application window. The main window title is "food KMSphere 3.1 (http://www.w3.org/2001/sw/WebOnt/guide-src/food)". The menu bar includes "File", "Edit", "Project", and "Help". The toolbar contains various icons for file operations and editing. The main workspace is titled "数据库本体学习" (Database Ontology Learning) and contains three buttons: "打开数据库" (Open Database), "本体编辑" (Ontology Edit), and "退出" (Exit). The main content area displays a list of database tables and their fields. A dialog box titled "本体编辑" (Ontology Edit) is open, showing a table with columns for "概念" (Concept), "数据属性" (Data Property), and "对象属性" (Object Property). The "数据属性" column contains the following entries:

概念	数据属性	对象属性
影院	HOTELNAME	
ENTERTAINMEN	HOTELADDRESS	
旅馆	HOTELTEL	
	HOTELPOST	

The dialog box also includes input fields for "旅馆" (Hotel) and "HOTELADDRESS", a "string" data type selection, and "保存Owl" (Save Owl) and "取消" (Cancel) buttons. The footer of the application window reads "中国科学院计算技术研究所智能信息处理重点实验室" (Key Laboratory of Intelligent Information Processing, Institute of Computing Technology, Chinese Academy of Sciences).

Ontology acquisition from databases

KMSphere Demo

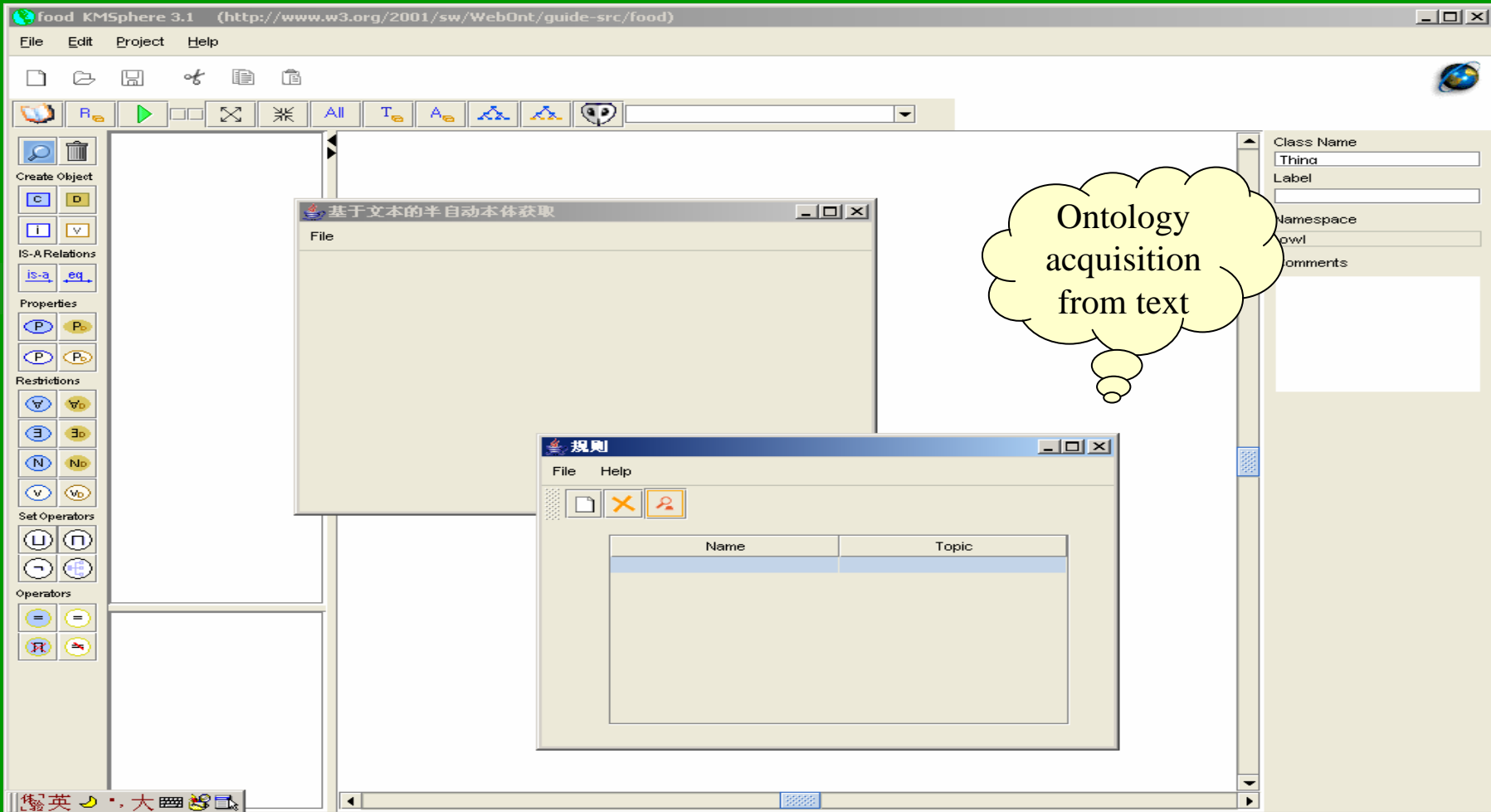

The screenshot displays the KMSphere 3.1 software interface. The main window title is "food KMSphere 3.1 (http://www.w3.org/2001/sw/WebOnt/guide-src/food)". The interface includes a menu bar (File, Edit, Project, Help), a toolbar with various icons, and a left sidebar with tool categories: Create Object, IS-A Relations, Properties, Restrictions, Set Operators, and Operators. A central workspace contains two windows: "基于文本的半自动本体获取" (Semi-automatic ontology acquisition from text) and "规则" (Rules). The "规则" window shows a table with columns "Name" and "Topic". A yellow thought bubble with the text "Ontology acquisition from text" is positioned over the main workspace. On the right side, there is a panel for class properties, including fields for Class Name, Label, Namespace, owl, and comments.

Name	Topic

KMSphere Demo

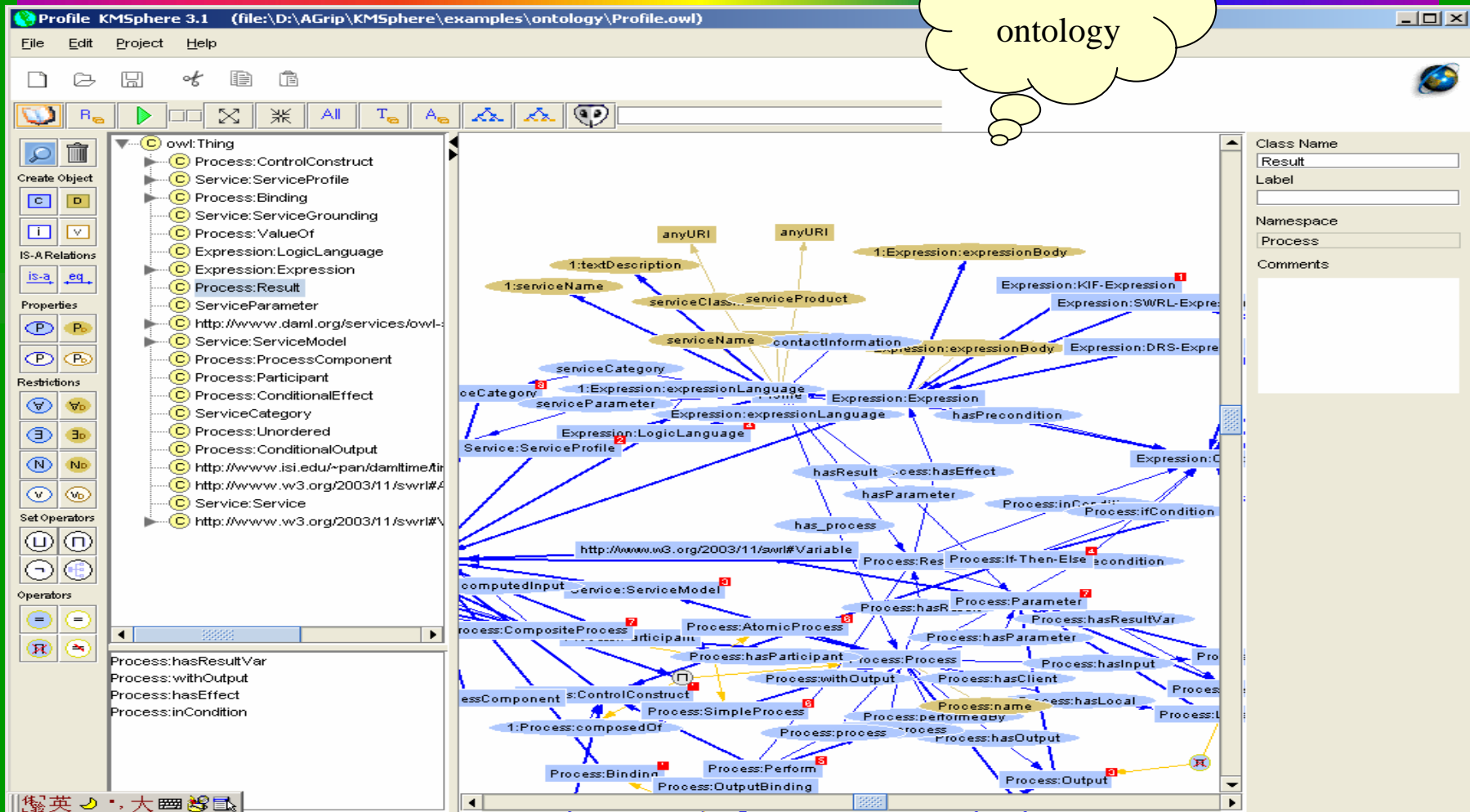

KMSphere Demo

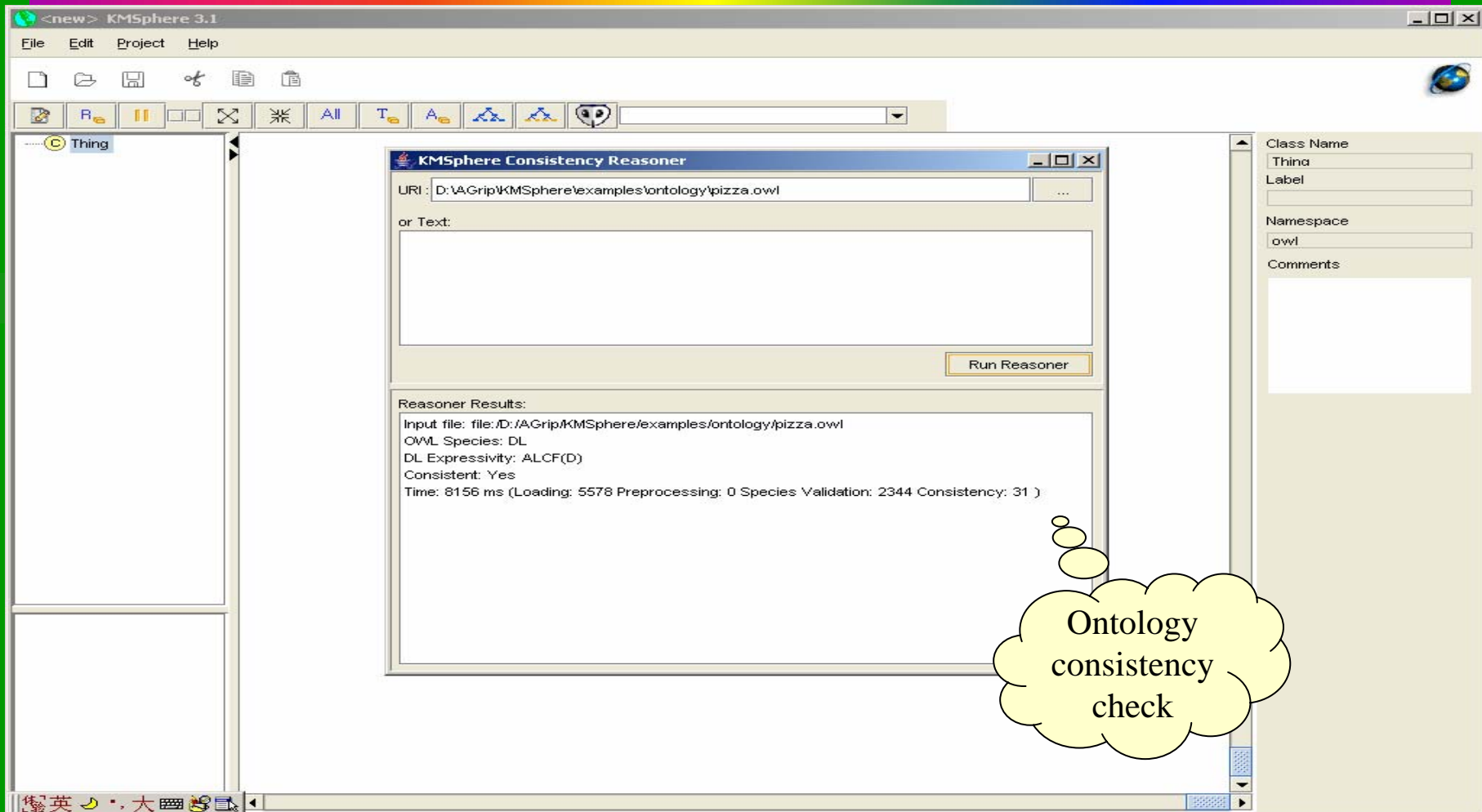

The screenshot displays the KMSphere 3.1 application window. The main interface includes a menu bar (File, Edit, Project, Help), a toolbar with various icons, and a central workspace. A floating window titled "KMSphere Consistency Reasoner" is open, showing the following details:

- URI: D:\AGrip\KMSphere\examples\ontology\pizza.owl
- or Text: (empty text area)
- Run Reasoner button
- Reasoner Results:
 - Input file: file:D:\AGrip\KMSphere\examples\ontology\pizza.owl
 - OWL Species: DL
 - DL Expressivity: ALCF(D)
 - Consistent: Yes
 - Time: 8156 ms (Loading: 5578 Preprocessing: 0 Species Validation: 2344 Consistency: 31)

On the right side of the main window, there is a panel with the following fields:

- Class Name: Thing
- Label: (empty)
- Namespace: owl
- Comments: (empty)

A yellow thought bubble with the text "Ontology consistency check" is positioned in the lower right area of the screenshot.

KMSphere Demo

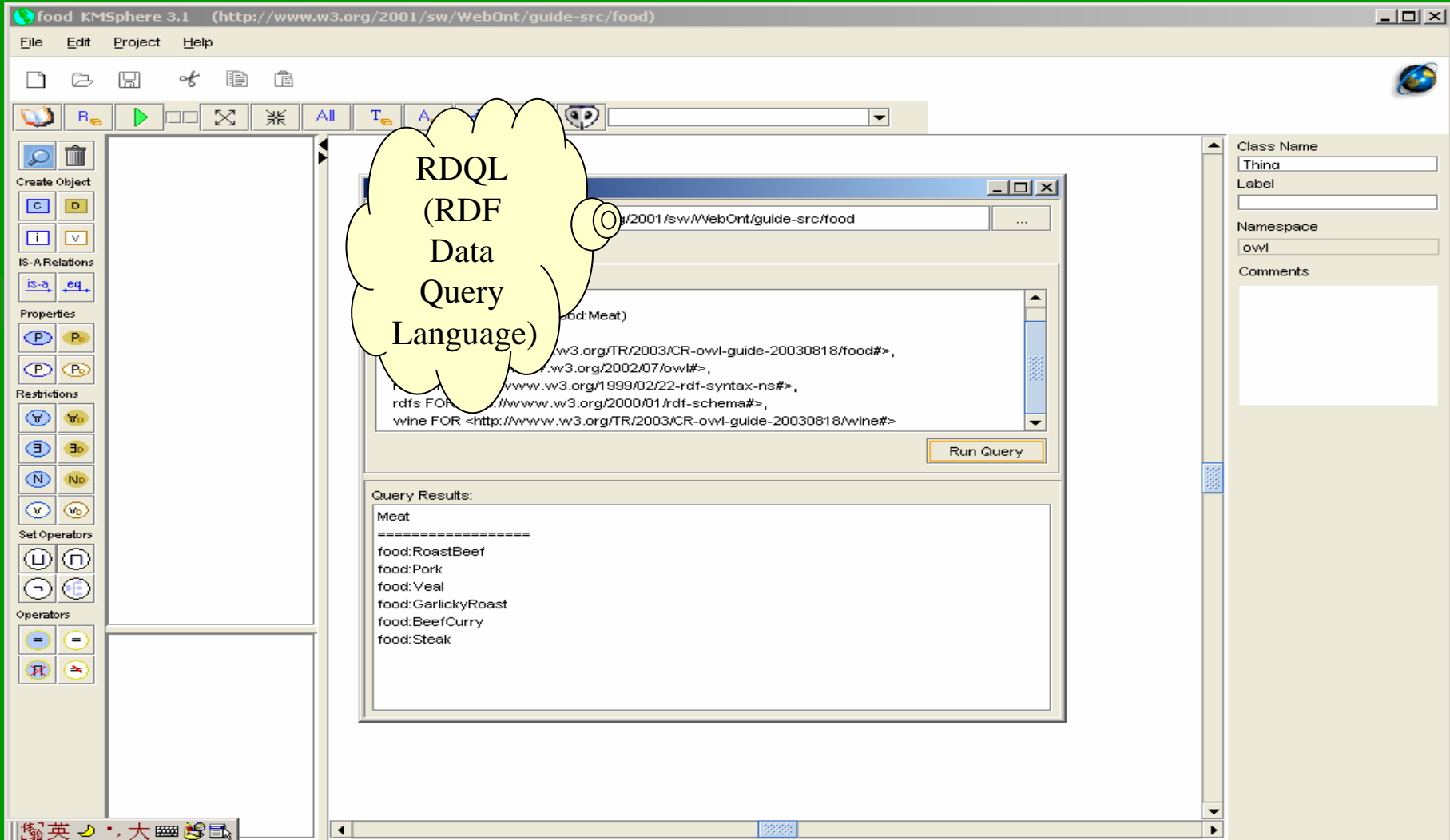

The screenshot shows the KMSphere 3.1 web interface. The main window displays a query editor with the following RDQL query:

```
SELECT ?x WHERE {  
  ?x rdfs:type food:Meat  
}
```

The query results are listed below:

```
Query Results:  
Meat  
-----  
food:RoastBeef  
food:Pork  
food:Veal  
food:GarlickyRoast  
food:BeefCurry  
food:Steak
```

A yellow callout bubble highlights the text "RDQL (RDF Data Query Language)".

The interface includes a menu bar (File, Edit, Project, Help), a toolbar, and a sidebar with various tool categories: Create Object, IS-A Relations, Properties, Restrictions, Set Operators, and Operators. The right sidebar shows metadata for the selected class, including Class Name (Thing), Label, Namespace (owl), and Comments.

Policy Driven

$$p = \langle S_{\text{trigger}}, A, S_{\text{goal}}, U \rangle$$

S_{trigger} : set of states for policy execution

A : set of actions

S_{goal} : set of goals

U : set of utility functions

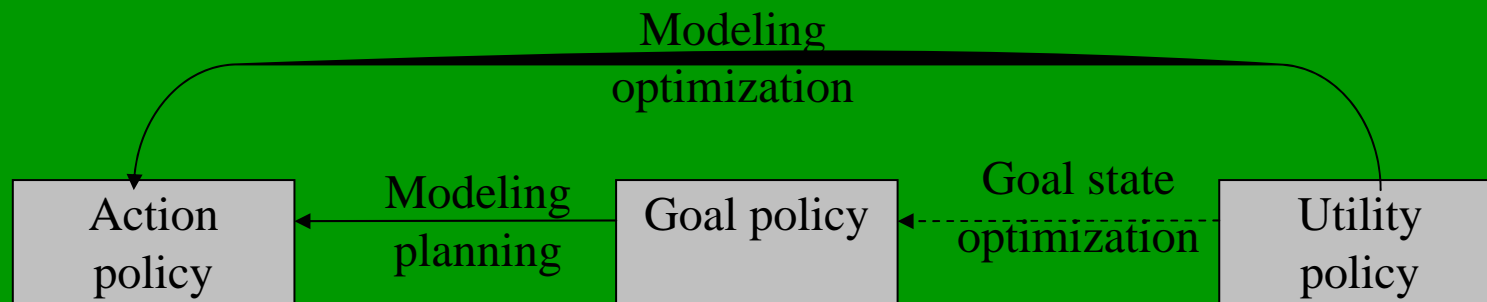

Plan Representation

A plan Π is a triple $\langle SO, OO, CS \rangle$

SO : a set of action-steps,

OO : a set of ordering constraints on the actions in SO .

CS : a set of variable-binding constraints between the variables of the action-steps in SO and other variables or constants.

Distributed Multiagent Plan Algorithm

Distributed – MultiAgent – Plan(OPS, CaS, I, G)

Input: a set of action-templates OPS ,
a set of capabilities of agents CaS ,
initial state I , and
goal G

Output: Plan Π

Distributed Multiagent Plan Algorithm

Procedure:

1. Inform all agents that I will start planning, and wait for them finishing current actions and entering plan state.
2. Initialize: Build an empty plan $\Psi = \langle SO, OO, CS, CLS \rangle$ where $CLS = \phi$
 $SO = \{Init, Goal\}$, $OO = \phi$, $CS = \phi$. Decompose goal G into a set of sub-goals GS through adding $\langle g, Goal \rangle$ to GS according to every literal $g \in G$.
3. Invoke recursive function $\phi = Generate - Next - Step(\Psi, GS)$
4. Taking effect: For each action executed by other agent, request it to add the action. For each constraint related to the actions executed by other agents, request it them to add the constraints.
5. Inform all agents the planning finishes, thus they can continue their plans.
6. If the invoking succeeds, then return success, otherwise return fault.

Outline

- Introduction
- Unified Communication
- Agent Collaboration
- Agent Grid Intelligence Platform
- Applications
- Conclusions

Agent Grid Intelligence Platform AGrIP

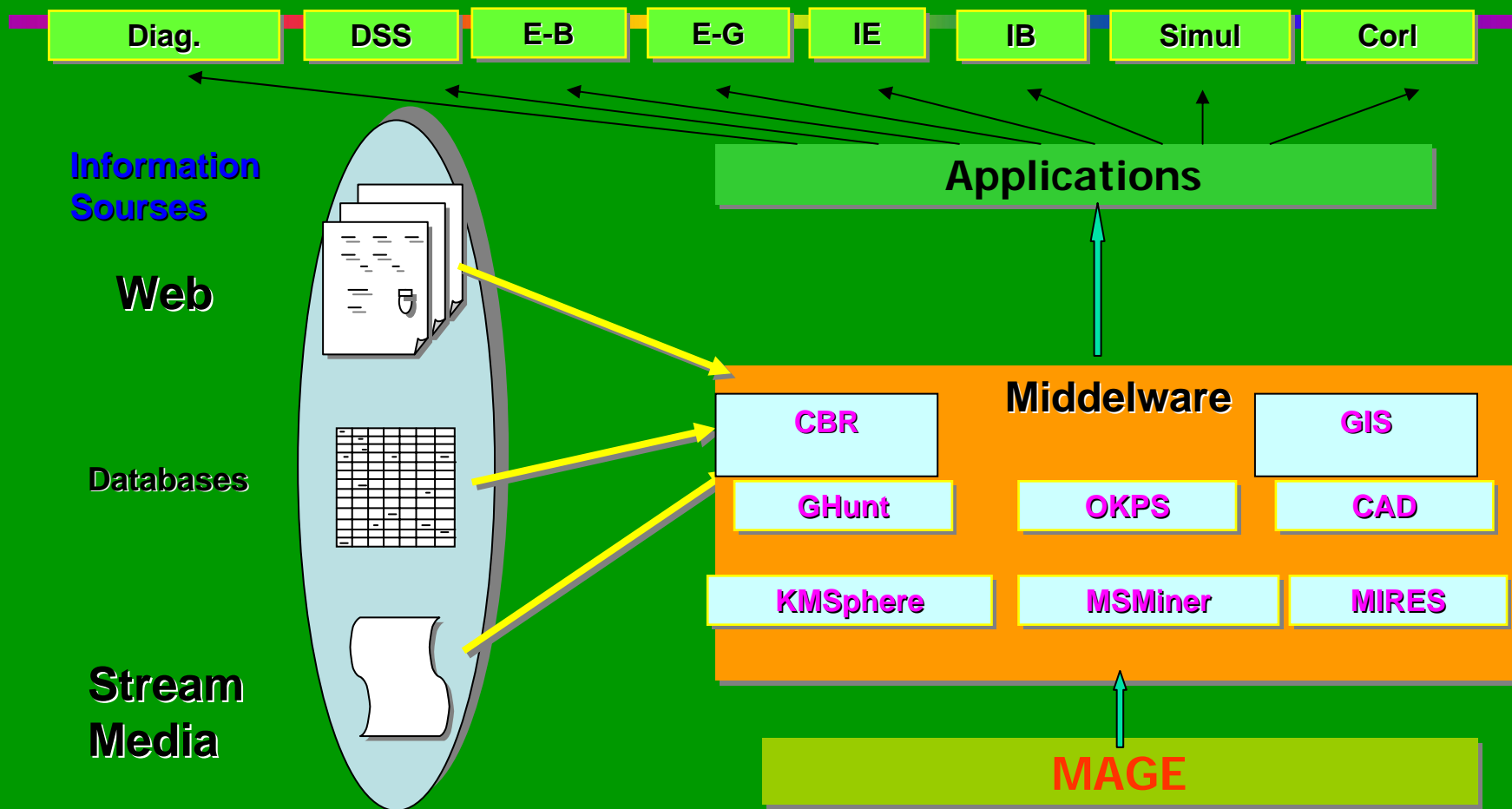

Data Mining Platform MSMiner

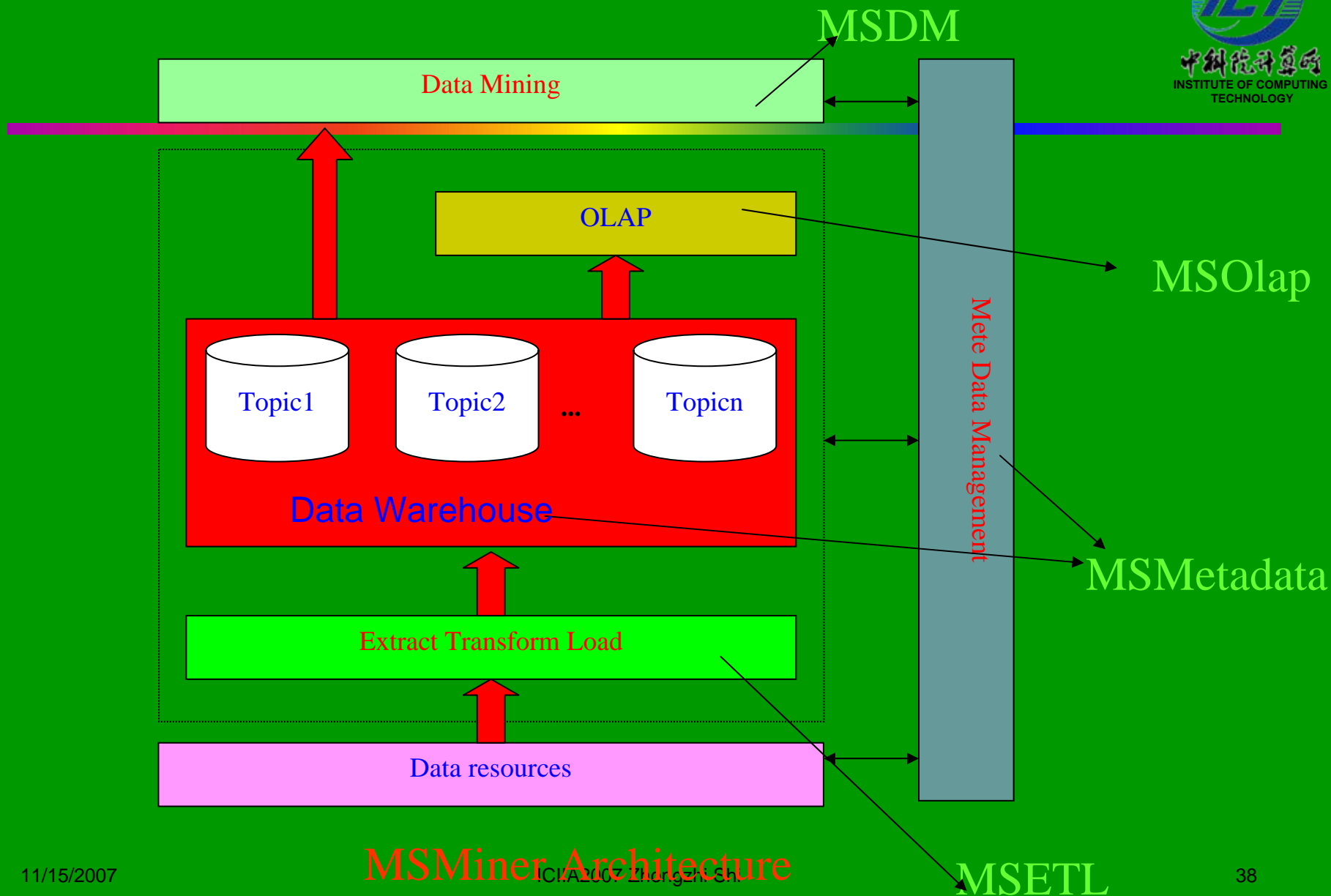

Expert System OKPS

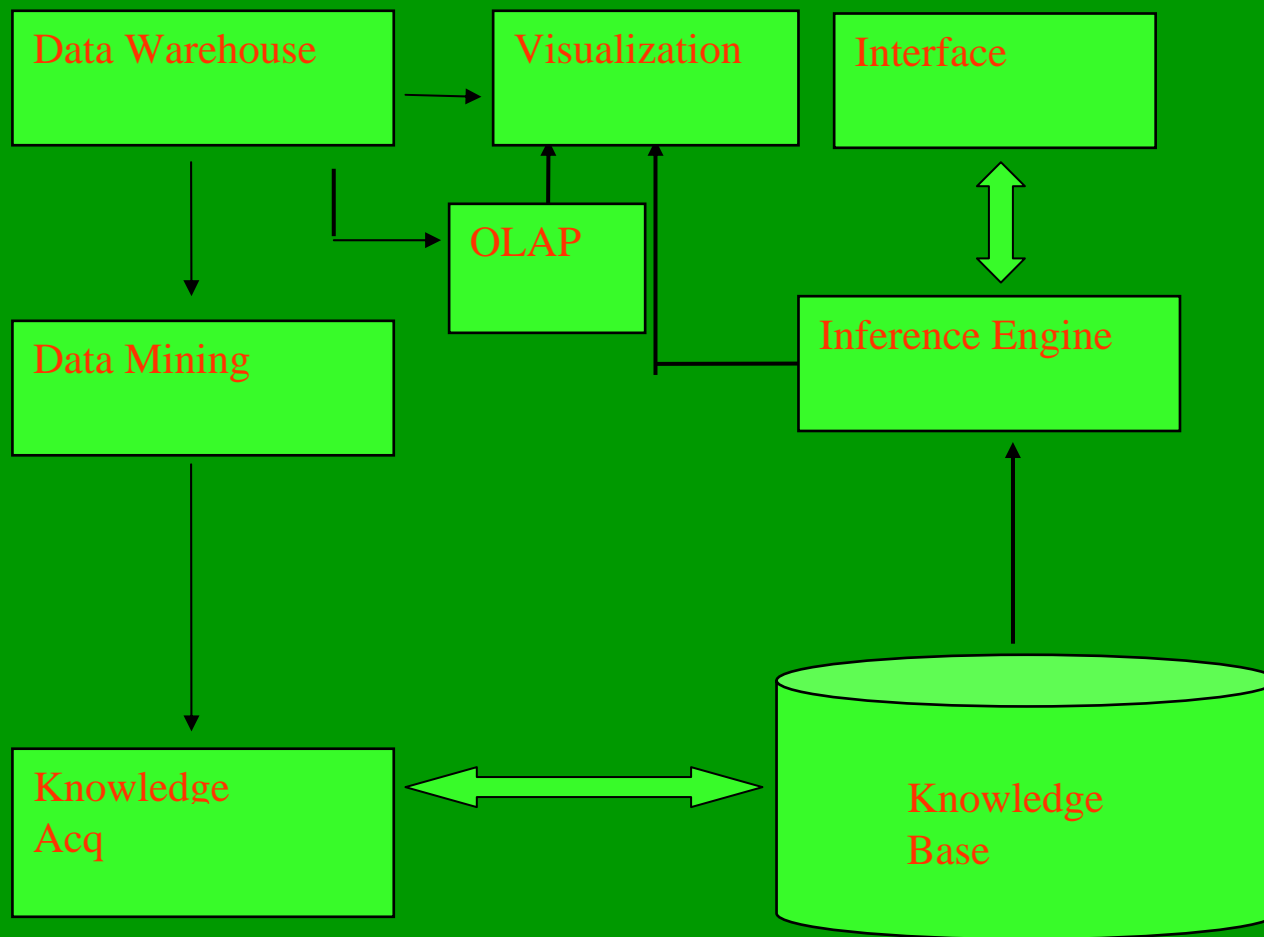

Outline

- Introduction
- Unified Communication
- Agent Collaboration
- Agent Grid Intelligence Platform
- Applications
- Conclusions

Emergency Interactive System GEIS

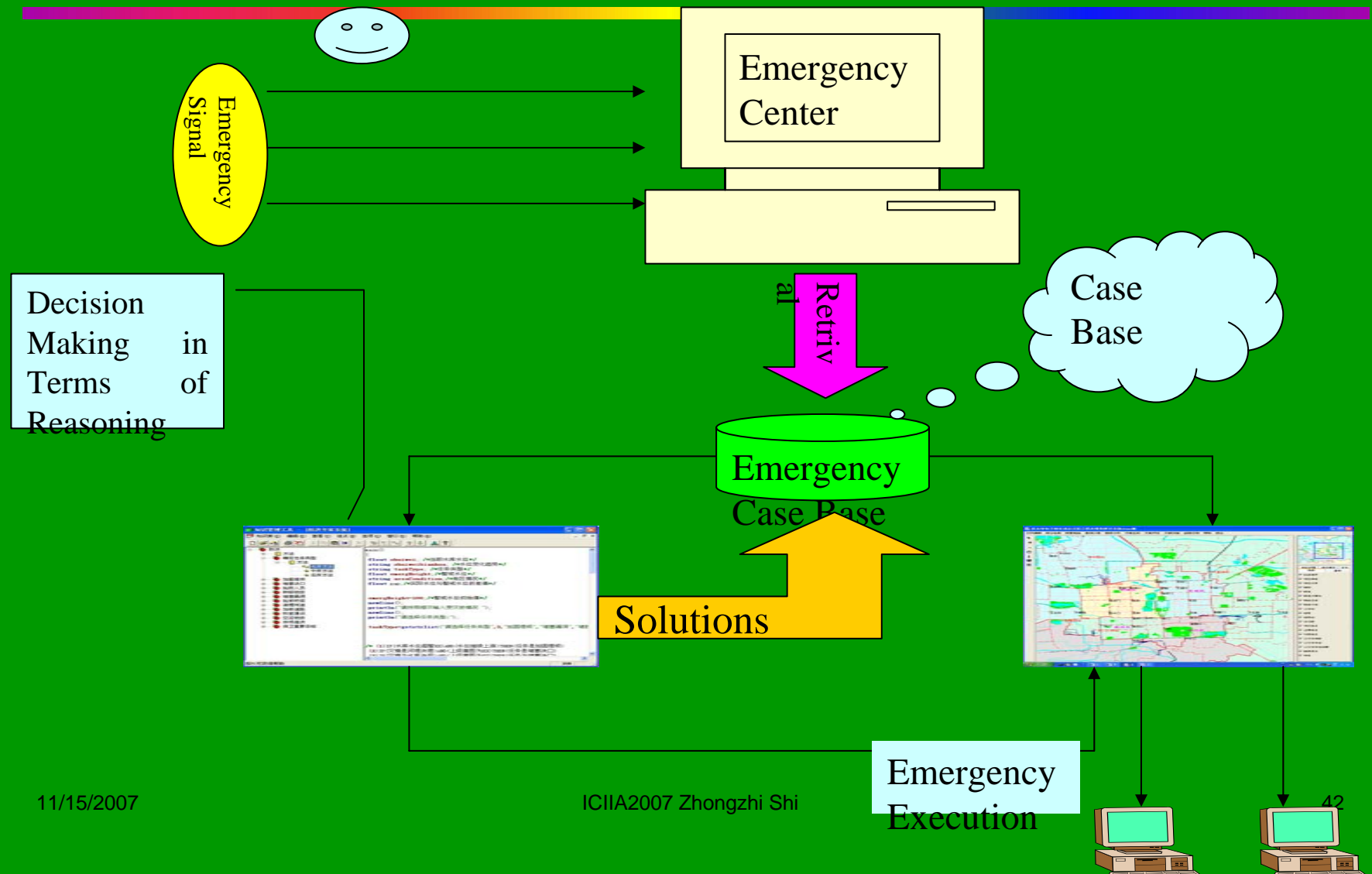

Emergency Interactive Architecture

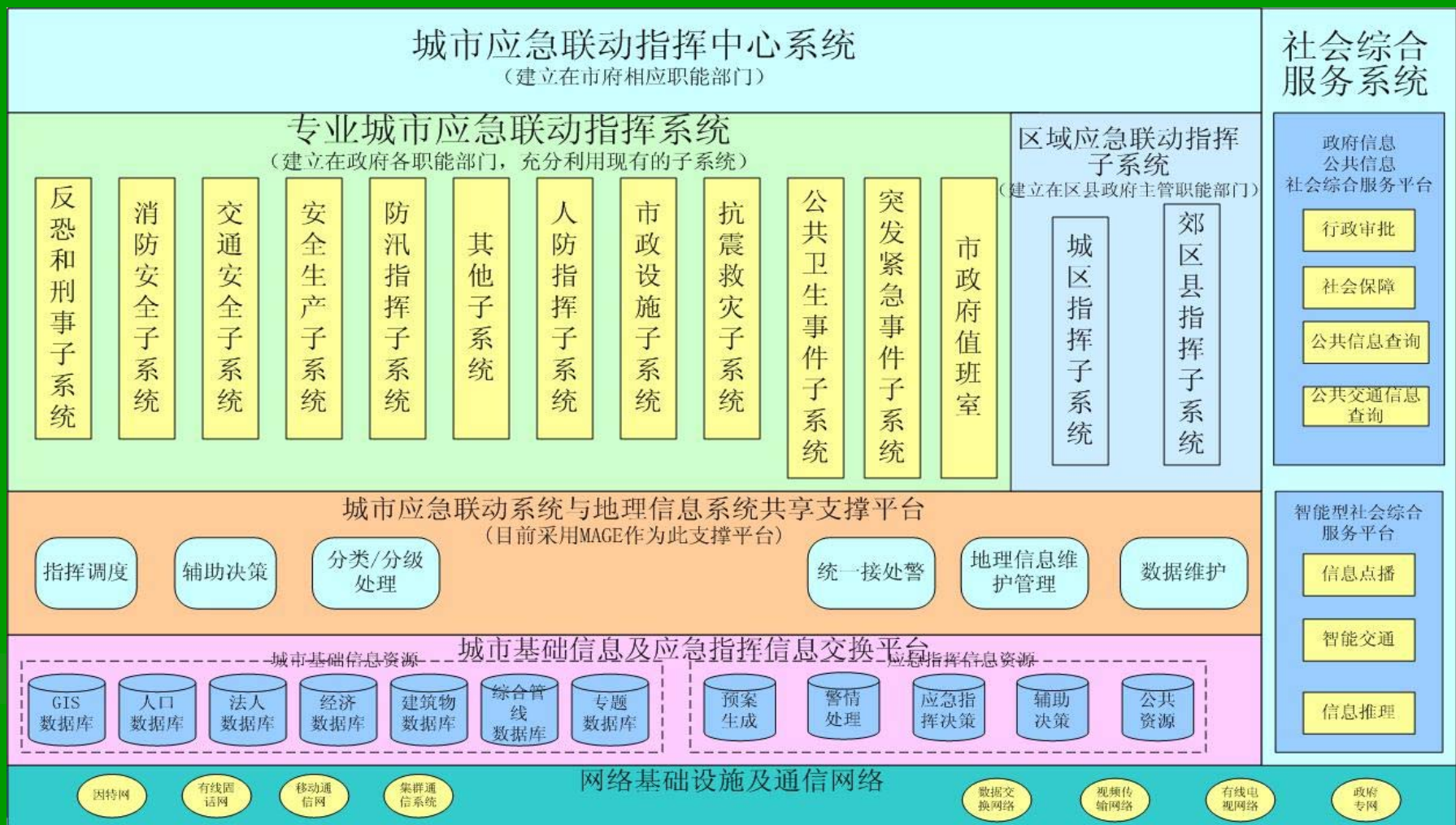

GEIS Interface

index.jsp - Microsoft Internet Explorer

文件(F) 编辑(E) 查看(V) 收藏(A) 工具(T) 帮助(H)

后退 前进 刷新 地址 搜索 收藏夹 媒体 打印

地址(D) http://192.168.0.212:8080/yjld/logon.do 转到 链接 >>



城市应急联动与社会综合服务系统

中国科学院计算技术研究所 北京曙光天演信息技术有限公司
北京军泰科技开发有限责任公司 北京市科瑞讯科技发展有限公司

[接警台](#) [处警台](#) [地图台](#) [社会综合服务系统](#)

请使用1024*768分辨率 2005版权所有

Intelligent Science Research Group, at Key Lab of ICT, CAS, China

Internet

Receive Crime Interface

接警台 - Microsoft Internet Explorer

接警台

>>基本信息<<

警情序号: 接警员:

警情地点:

报警人名: 性别: 男 女

报警人电话: 接警员:

编号	接警员	值班领导	事故类型	发案地点	接警时间	警情状态
282	施智平	尹超	1	三里屯	2006-01-11	正在处理.....
283	施智平	尹超	6	西直门	2006-01-13	正在处理.....
287	施智平	尹超	6	西直门	2006-02-18	正在处理.....
286	施智平	尹超	1	西直门	2006-02-23	正在处理.....
				三里屯	2006-03-07	正在处理.....

>>警情细节<<

事故等级: 天气:

指挥长: 处警员:

事故对象: 事故分:

火情: 有 无 死伤人:

危险品: 有 无 丧失行数:

损失折款: 元

警情概要:

未警!!! - Microsoft Internet Explorer

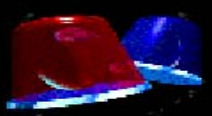

Process Crime Interface



外警页面 - Microsoft Internet Explorer
处警台

>>基本信息<<

警情序号:	<input type="text" value="1"/>	接警员:	<input type="text" value="施智平"/>
警情地点:	<input type="text" value="西直门"/>	<input type="button" value="地点定位"/>	<input type="button" value="清除路线"/>
报警人名:	<input type="text" value="罗杰文"/>		
报警人电话:	<input type="text" value="01062565533"/>	接警时间:	<input type="text" value="2006-01-09 00:00:00"/>

>>警情细节<<

事故等级:	<input type="text" value="1"/>	天气:	<input type="text" value="晴朗"/>
指挥长:	<input type="text" value="尹超"/>	处警员:	<input type="text" value="余清"/>
事故对象:	<input type="text" value="机动货车"/>	事故分类:	<input type="text" value="超速驾驶"/>
火情:	<input checked="" type="radio"/> 有 <input type="radio"/> 无	死伤人数:	死: <input type="text" value="1"/> 伤: <input type="text" value="2"/>
危险品:	<input checked="" type="radio"/> 有 <input type="radio"/> 无	损毁车辆数:	<input type="text" value="0"/> 辆
警情概要:	<input type="text" value="有行人受伤"/>		
损失折款:	<input type="text" value="10000"/> 元	<input type="button" value="修改警情"/>	

>>处警协同<<

处警操作:	<input type="button" value="方案生成"/>	<input type="button" value="方案通知"/>	<input type="button" value="方案打印"/>
到达现场时间:	<input type="text"/>	<input type="button" value="now"/>	<input type="button" value="到达现场"/>
反馈时间:	<input type="text"/>	<input type="button" value="now"/>	<input type="button" value="收到反馈"/>
处理完毕时间:	<input type="text"/>	<input type="button" value="now"/>	<input type="button" value="处警完毕"/>

>>处警方案<<

交警单位:	<input type="text" value="西城交警支队"/>	<input type="button" value="路线"/>	<input type="button" value="优化"/>	人数:	<input type="text" value="3"/>
医护单位:	<input type="text" value="人民医院"/>	<input type="button" value="路线"/>	<input type="button" value="优化"/>	车数:	<input type="text" value="2"/>
消防单位:	<input type="text" value="北京西城区西直门消防中队"/>	<input type="button" value="路线"/>	<input type="button" value="优化"/>	车数:	<input type="text" value="2"/>
路政单位:	<input type="text" value="东城区路政"/>	<input type="button" value="路线"/>	<input type="button" value="优化"/>	人数:	<input type="text" value="3"/>

处理方法:

- 1、消防人员、器材、车辆赴现场灭火和抢险救援。
- 2、警察维持秩序，保证灭火工作进行，必要时对事故现场可采取临时交通管制措施。
- 3、医务人员和救护车赴现场抢救伤员。
- 4、交警勘察现场、拍照，认定事故原因。
- 5、交警尽快处理现场，路政人员迁移肇事车辆，恢复交通。

编号	接警员	值班领导	事故类型	发案地点	接警时间	警情状态
282	施智平	尹超	1	三里屯	2006-01-11	正在处理.....
283	施智平	尹超	6	西直门	2006-01-13	正在处理.....
287	施智平	尹超	6	西直门	2006-02-18	正在处理.....
286	施智平	尹超	1	西直门	2006-02-18	正在处理.....
290	施智平	尹超	6	西直门	2006-02-23	正在处理.....
289	施智平	尹超	1	三里屯	2006-02-27	正在处理.....

Geographical Information System



信息产业部应急联动系统-地理信息子系统 - Microsoft Internet Explorer

文件(E) 编辑(E) 查看(V) 收藏(A) 工具(T) 帮助(H)

地址(D) <http://192.168.0.212:8080/yjld/default.html>

地图操作
图标编辑
标图作业
空间分析
统计图形

欢迎使用本系统... 11/15/2007

Internet

CBR-Based Reserve Plan Against Emergency

预案查询页面 - Microsoft Internet Explorer

地址(D) http://192.168.0.212:8080/yjld/jsp/accidentRef.jsp?AccidentNum=1

城市应急联动与社会综合服务系统>>>交通安全指挥子系统>>>预案生成

预案(CBR)

- case_16__57.02%
- case_11__56.69%
- case_18__56.43%
- case_17__54.82%

综合预案

>>预案警情<<

事故地点: 西单
 事故等级: 2
 事故对象: 自行车
 火情: 有 无
 危险品: 有 无
 损失折款: 10000 元
 警情概述: 小客车撞倒自行车

天气: 晴朗
 事故分类: 超速驾驶
 死伤人数: 死 1 伤 2
 损毁车辆: 1 辆

>>参考预案<<

交警单位	西城交警支队	人数:	3	选用 清除
救护单位	北京市崇文区急救站	车数:	2	选用 清除
消防单位		车数:		选用 清除
路政单位		车数:		选用 清除

建议处警方法:

- 1、市公安局、市公安交通管理局迅速组织警力赴现场调查处理事故,维护现场秩序,参加救援工作。
- 2、市卫生局迅速调集医务人员和车辆赴现场抢救伤员。
- 3、交警勘察现场、拍照,认定事故原因。
- 4、交警尽快处理现场,恢复交通。

选用
清除

>>现场警情<<

事故地点: 西直门
 事故等级: 1
 事故对象: 机动货车
 火情: 有 无
 危险品: 有 无
 损失折款: 10000元
 警情概述: 有行人受伤

天气: 晴朗
 事故分类: 超速驾驶
 死伤人数: 死 1 伤 2
 损毁车辆: 0 辆

>>决心方案<<

交警单位	西城交警支队	人数:	3	选用 清除
救护单位	北京市崇文区急救站	车数:	2	选用 清除
消防单位		车数:		选用 清除
路政单位		车数:		选用 清除

处警方法:

11/15/2007

ICIA2007 Zhongzhi Shi

Internet

48

CBR-Based Reserve Plan Against Emergency

预案查询页面 - Microsoft Internet Explorer

文件(F) 编辑(E) 查看(V) 收藏(A) 工具(T) 帮助(H)

后退 前进 刷新 搜索 收藏夹 媒体

地址(D) http://192.168.0.212:8080/yjld/jsp/accidentRef.jsp?AccidentNum=1

转到 链接 >>

预案(CBR) 城市应急联动与社会综合服务系统>>>交通安全指挥子系统>>>预案生成

预案(RBR)

RBR结果

>>现场警情<<

事故地点:	西直门	警情序号:	1
事故等级:	1	天气:	晴朗
事故对象:	机动货车	事故分类:	超速驾驶
火情:	<input type="radio"/> 有 <input checked="" type="radio"/> 无	死伤人数:	死: 1 伤: 2
危险品:	<input type="radio"/> 有 <input checked="" type="radio"/> 无	损毁车辆:	0 辆
损失折款:	10000元		
道路设施受损描述:	有行人受伤		

>>决心方案<<

事故等级:	重大事故
交警人数:	10
路政人数:	5
消防车数:	0
救护车数:	3

处警方法:

(1) 市公安局、市公安交通管理局迅速组织警力赴现场调查处理事故, 维护现场秩序, 参加救援工作。(2) 市卫生局迅速调集医务人员和车辆赴现场抢救伤员。(3) 事故发生所在地区县人民政府、事故单位上级主管部门的负责同志立即赴现场处理事故。

综合预案

完毕

11/15/2007

ICIA2007 Zhongzhi Shi

Internet

49



国家电网
STATE GRID

国网北京经济技术研究院
STATE GRID ECONOMIC RESEARCH INSTITUTE

Power Supply Simulation



Department need simulation

二次滑动平均

向前预测步数: 2

F检验显著性水平: 全口径 基本 公报

误差评价标准: 类型值 当期值 时点 实际值

GDP参照年份: 时间类型: 年 地域: 全国

预测模型选择: 宏观经济指数

开始时间: 2004-01-01 结束时间: 2004-01-01

参数设置

电力供需预测分析实验平台 PowerLab

文件 配置 调整规则 帮助

预测模型树:

- 时间序列外推模型
 - 一次指数平滑
 - 二次指数平滑
 - 三次指数平滑
 - 非齐次指数模型
 - 逻辑斯蒂模型
 - 指数曲线模型
 - 灰色模型
 - 神经网络模型
- 因素分析预测模型
 - 知识库模型
 - 需求侧管理政策模拟
 - 初始状态及报告
 - 经济类政策
 - 技术类政策
 - 综合类政策
 - 宏观政策模拟
 - 初始状态
 - 政策实施状态

数据源1 分支:

- 灰色模型1 (23612.8 28739.4) -> 数据图表2
- 逻辑斯蒂模型1 (20123.3 22436.6) -> 数据图表1
- 指数曲线模型1 (26972.0 30154.0) -> 数据图表3
- 神经网络模型1 (15254.5 15420.5) -> 数据图表5

执行

预测步数=2

预测结果:

20123.389999999998
22436.699999999997

显示数据图表成功
执行成功!

电力供需预测分析实验平台PowerLab©copyright 2006, Mailto:inf@ics.ict.ac.cn

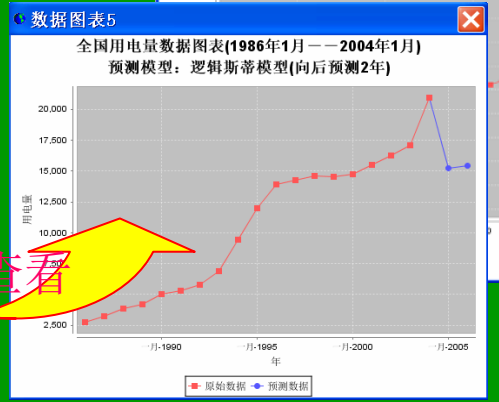
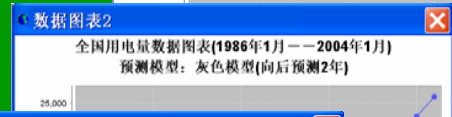
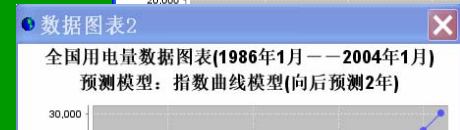
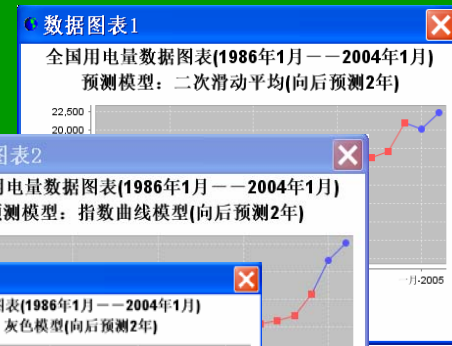

参数设置

结果查看



Policy simulation

The screenshot displays the PowerLab simulation environment. On the left, a tree view shows the simulation structure, including '需求侧管理政策模型' (Demand Side Management Policy Model) and '政策实施状态' (Policy Implementation Status). The main workspace shows a flow diagram with nodes for '峰谷分时电价2', '可中断负荷1', and '管理引导性政策2', leading to '初始状态2', '政策实施状态3', and '政策实施状态4'. A yellow box labeled '执行' (Execute) is positioned over the flow diagram.

Several configuration windows are open:

- 管理引导性政策** (Management Guidance Policy): Includes settings for electricity saving intensity, industry selection, and cost distribution.
- 峰谷分时电价** (Peak-Valley Time-of-Day Pricing): Includes settings for industry selection, peak/off-peak prices, and implementation costs.
- 可中断负荷** (Interruptible Load): Includes settings for industry selection, interruptible load capacity (KVA), and implementation costs.

Simulation results are shown in multiple charts:

- 峰谷分时电价** (Peak-Valley Time-of-Day Pricing): Shows '节电量 万kWh' (Energy Savings in 10,000 kWh) and '削减高峰负荷 万kW' (Peak Load Reduction in 10,000 kW).
- 可中断负荷** (Interruptible Load): Shows '节电量 万kWh' and '削减高峰负荷 万kW'.
- 管理引导性政策** (Management Guidance Policy): Shows '节电量 万kWh', '削减高峰负荷 万kW', and '节成本 万元' (Cost Savings in 10,000 Yuan).

Yellow callouts with red text highlight '参数设置' (Parameter Settings) pointing to the configuration windows, and '结果查看' (Result Viewing) pointing to the simulation results charts.

Fish Field Forecast in Eastern Sea of China

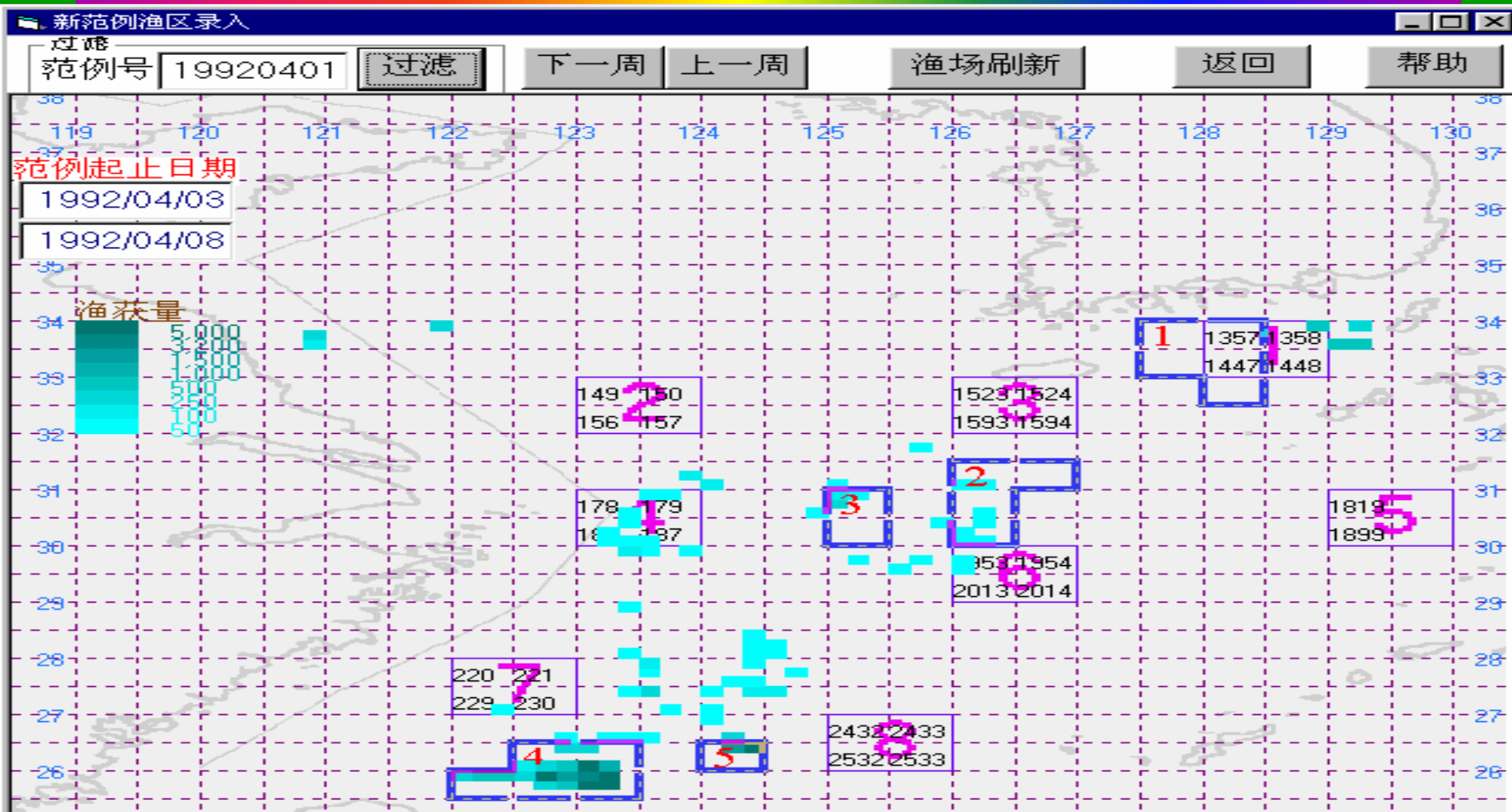

DSS for Oil Pipeline Design

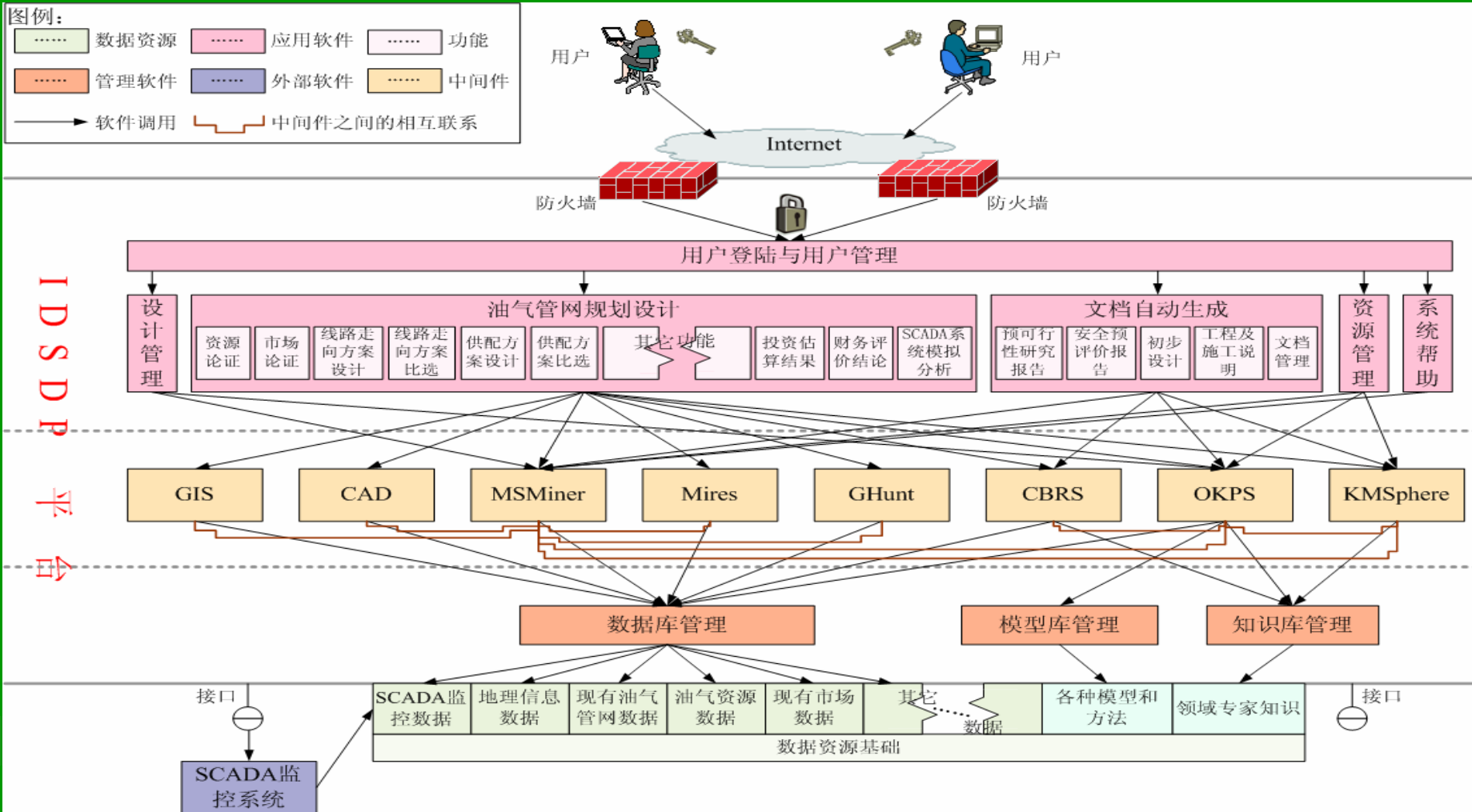

Conclusions

- **Unified Communication**
- **Collaboration**
- **AGrIP is a Collaborative Environment for Constructing Large Complex Systems**
- **Applications**

THANK YOU!

Question!



Intelligence Science
<http://www.intsci.ac.cn/>